

# ICC-ES Evaluation Report

**ESR-5030**



Reissued June 2025

Subject to renewal June 2026



ICC-ES Evaluation Reports are not to be construed as representing aesthetics or any other attributes not specifically addressed, nor are they to be construed as an endorsement of the subject of the report or a recommendation for its use. There is no warranty by ICC Evaluation Service, LLC, express or implied, as to any finding or other matter in this report, or as to any product covered by the report.

Copyright © 2025 ICC Evaluation Service, LLC. All rights reserved.

<p><b>DIVISION: 05 00 00— METALS</b></p> <p><b>Section: 05 05 23— Metal Fastenings</b></p> <p><b>DIVISION: 06 00 00— WOOD, PLASTICS AND COMPOSITES</b></p> <p><b>Section: 06 16 00— Sheathing</b></p>	<p><b>REPORT HOLDER:</b></p> <p><b>AEROSMITH FASTENING SYSTEMS</b></p> 	<p><b>EVALUATION SUBJECT:</b></p> <p><b>AEROSMITH FASTENERS (2385AG, 2359NG and 5454 HPG) USED IN HORIZONTAL DIAPHRAGMS</b></p>	
---	--	---	---

## 1.0 EVALUATION SCOPE

**Compliance with the following codes:**

- 2021, 2018, 2015 and 2012 [International Building Code® \(IBC\)](#)
- 2021, 2018, 2015, and 2012 [International Residential Code \(IRC\)](#)

**Property evaluated:**

Structural

## 2.0 USES

The Aeromsmith Fasteners (2385AG, 2359NG and 5454 HPG) are pneumatically driven fasteners used to attach floor and roof sheathing to cold-formed steel framing (CFS) members. The fasteners may be used to attach wood sheathing to CFS in structures regulated by the IRC, provided an engineered design is submitted in accordance with Section R301.1.3 of the IRC.

## 3.0 DESCRIPTION

**3.1 Aeromsmith 2385AG and 2359NG Fasteners:** The Aeromsmith 2385AG and 2359NG fasteners are Aeromsmith VersaPin fasteners heat treated to a Rockwell C hardness between 52 and 55, with a minimum tensile strength of 240 ksi and a bending yield strength of 250 ksi (1724 MPa). The fasteners are zinc electroplated with a chromate rinse, mechanically zinc plated ASTM B633 Type 1 SC, ASTM B695 Type 1 Class 5 or a nickel metal alloy. The plating is a minimum thickness of 0.0002 inch (0.0051 mm) thick.

The fasteners are manufactured with a knurled shank with a nominal finished shank diameter of 0.100 inch (2.54 .3

mm). The 2385AG fastener has a ballistic end point and the 2359NG fastener has a SuperSharp end point. See [Table 1](#) and [Figure 1](#) for fastener dimensions and images. The fasteners are collated for powered installation tools.

**3.2 Aerosmith 5454HPG Fasteners:** The Aerosmith 5454HPG fasteners are Aerosmith PowerPin fasteners manufactured from AISI 1060 steel, heat treated to a Rockwell C hardness between 52 - 55 for the core and a R45N surface hardness between 39 - 50 for the surface, and have a minimum tensile strength of 65,000 psi (448 MPa). The pins are zinc electro-plated with a chromate rinse, are mechanically zinc plated, or use a nickel alloy electro-plate. The fasteners are designed with a knurled shank profile and a ballistic end point. See [Table 1](#) and [Figure 1](#) for fastener dimensions and images. The fasteners are collated for powered installation tools.

**3.3 Floor and Roof Sheathing:** Fasteners may be used for installation with the following types of sheathing.

- $1\frac{5}{32}$  inch (23.8 mm) or  $1\frac{1}{8}$  inch (28.6 mm) Plywood complying with USDC Product Standard PS-1 or PS-2-92.
- $\frac{7}{16}$  inch (11.1 mm) or  $\frac{19}{32}$  inch (15.1 mm) OSB panels, Structural 1, Exposure 1, complying with DOC PS-2.

**3.4 Cold Formed Steel:** The cold-formed steel shall comply with AISI S100 and have a minimum base metal thickness of 20 gage (33 mils).

## 4.0 DESIGN AND INSTALLATION

**4.1 Design:** Diaphragm analysis must comply with the applicable requirements of the IBC Chapter 16.

The ultimate shear loads for cantilever horizontal diaphragms are presented in [Table 2](#).

**4.2 Installation:**

**4.2.1 General:** The fasteners must be installed in accordance with this report and the Aerosmith Fastening Systems published installation instructions. A copy of these instructions must be available on the jobsite at all times during installation.

The fasteners are installed with a power fastening tool in accordance with Aerosmith Fastening Systems recommendations. The fastener penetration, spacing and edge distances must be as noted in the tables of this report.

When used in floor sheathing applications, installation must be limited to weather-protected, interior locations; for use in roof sheathing applications, the panels must be protected by an approved roof covering. In accordance with Section 2304.10.6.4 and the Exception to IBC Section 2304.10.6.1 of the 2021 IBC (Section 2304.10.5.4 and the Exception to IBC Section 2304.10.5.1 of the 2018 and 2015 IBC; Section 2304.9.5.4 and the Exception to IBC Section 2304.9.5.1 of the 2012 IBC), the nickel alloy plated Aerosmith fasteners may be used in SBX/DOT and zinc borate preservative-treated wood and fire-retardant treated wood, based on the Aerosmith recommendations.

## 5.0 CONDITIONS OF USE:

The Aerosmith Fasteners (2385AG, 2359NG and 5454 HPG) described in this report comply with, or are suitable alternatives to what is specified in, those codes listed in section 1.0 of this report, subject to the following conditions:

- 5.1** The fasteners must be manufactured and identified in accordance with this report.
- 5.2** Fastener installation must comply with this report and Aerosmith Fastening Systems' published installation instructions. In the event of a conflict between this report and the Aerosmith Fastening Systems published installation instructions, the more restrictive requirements govern.
- 5.3** Calculations demonstrating that the applied loads are less than the allowable loads described in this report must be submitted to the code official. The calculations must be prepared by a registered design professional where required by the statutes of the jurisdiction in which the project is to be constructed.
- 5.4** The use of fasteners in contact with preservative-treated or fire-retardant-treated wood is outside the scope of this report.
- 5.5** The fasteners are manufactured under a quality control program with inspections by ICC-ES.

## 6.0 EVIDENCE SUBMITTED

- 6.1** Cantilever floor diaphragm test data in accordance with AISI S907.
- 6.2** Static load testing data in accordance with ASTM E455.
- 6.3** Quality documentation in accordance with [ICC-ES Acceptance Criteria for Quality Documentation \(AC10\)](#).

## 7.0 IDENTIFICATION

7.1 The containers of the fasteners must be labeled with the report holder's name (Aerosmith Fastening Systems), address or website, the product name, fastener designation, catalog number, lot number and manufacturing plant identification/traceability and the evaluation report number (ESR-5030). In addition, the fasteners are identified by the logo symbol stamped into the fastener head as shown in [Figure 1](#).

7.2 The report holder's contact information is the following:

**AEROSMITH FASTENING SYSTEMS**  
**5621 DIVIDEND ROAD**  
**INDIANAPOLIS, INDIANA 46241**  
**(800) 528-8183**  
[www.aerosmithfastening.com](http://www.aerosmithfastening.com)  
[info@aerosmithfastening.com](mailto:info@aerosmithfastening.com)

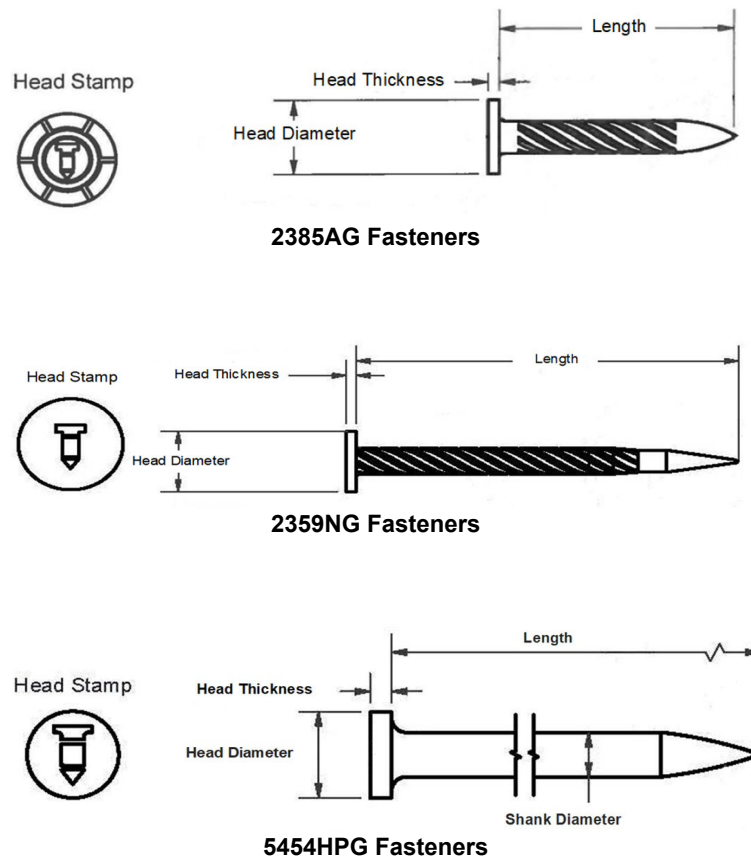

FIGURE 1—AEROSMITH FASTENERS

**TABLE 1—AEROSMITH FASTENERS**

FASTENER	SHANK TYPE	POINT TYPE	SHANK DIAMETER (inch)	HEAD DIAMETER (inch)	LENGTH (inch)	FASTENER COATING
2385AG	Gripshank	Ballistic	0.100	0.312	1.500	Zinc
2359NG	Gripshank	SuperSharp	0.100	0.250	1.500	Zinc
5454HPG	Knurled	Ballistic	0.145	0.300	1.750	Zinc

For SI: 1 inch = 25.4 mm.

**TABLE 2—ULTIMATE SHEAR LOADS FOR CANTILEVER DIAPHRAGMS**

SHEATHING	FASTENER	FASTENER SPACING (EDGE:FIELD)	MINIMUM EDGE DISTANCE	STEEL STUD			ULTIMATE SHEAR LOAD (ϕf)
				GAGE (mils)	TENSILE STRENGTH (ksi)	MAXIMUM STUD SPACING (inch)	
1 <sup>5</sup> / <sub>32</sub> " Plywood	2385AG	6:6	3/8	16 (54)	50	24	626
7 <sup>7</sup> / <sub>16</sub> " OSB	2359NG	6:6	3/8	20 (33)	65	24	468
1-1 <sup>1</sup> / <sub>8</sub> " PLYWOOD	5454HPG	6:6	3/8	14 (68)	50	48	893
1 <sup>9</sup> / <sub>32</sub> " OSB	5454HPG	6:12	3/8	14 (68)	50	24	550

For SI: 1 foot = 305 mm, 1 inch = 25.4 mm, 1 pound = 4.45 N. 550

<sup>1</sup>Refer to Table 3 for applicable diaphragm safety (Ω) and load resistance (ϕ) factors corresponding to ASD, LRFD and/or LSD design methods.

<sup>2</sup>The maximum aspect ratio for cantilever diaphragms is 1:1.

<sup>3</sup>Diaphragm stiffness must be determined by rational engineering analysis. Conservatively can use worst-case scenario between rigid or flexible assumptions. The deflection of diaphragm shall be determined by principle of mechanics considering the deformation of the sheathing, attachment of sheathing, chords and collectors.

<sup>4</sup>Steel joists shall conform to AISI.

<sup>5</sup>Values are "Unblocked Diaphragms" decking attached with long panel direction perpendicular to joists.

**TABLE 3—ALLOWABLE DESIGN SAFETY FACTORS AND STRENGTH REDUCTION FACTORS FOR WOOD STRUCTURAL SHEATHING TO COLD FORM STEEL JOIST DIAPHRAGMS**

SHEATHING	FASTENER	EARTHQUAKE		WIND	
		Ω (ASD)	ϕ (LRFD)	Ω (ASD)	ϕ (LRFD)
1 <sup>5</sup> / <sub>32</sub> " Plywood	2385AG	3.12	0.59	2.49	0.64
7 <sup>7</sup> / <sub>16</sub> " OSB	2359NG	3.28	0.56	2.63	0.61
1-1 <sup>1</sup> / <sub>8</sub> " PLYWOOD	5454HPG	3.01	0.61	2.41	0.67
1 <sup>9</sup> / <sub>32</sub> " OSB	5454HPG	3.18	0.58	2.54	0.63

For SI: 1 foot = 305 mm, 1 inch = 25.4 mm, 1 pound = 4.45 N.

<sup>1</sup>Tabulated values have been evaluated for horizontal diaphragm use only.

<sup>2</sup>Safety factors and resistance factors for wood subfloor diaphragms installed over cold-formed steel framing are based upon AISI S100-2016, Section B5.4.3, S400-15/s1-16, Section F2.4.2, Section K2.1.1, K2.12

<sup>3</sup>Safety factors and resistance factors for diaphragms installed over steel joists are based on the worst case of the standard factors from the American Wood Council Special Design Provisions for Wind and Seismic (AWC SDPWS-2008) and those tabulated for steel framing.