

ICC-ES Evaluation Report

ESR-3833

Reissued August 2025

This report also contains:

- [City of LA Supplement](#)



Subject to renewal August 2026

- [CA Supplement](#)

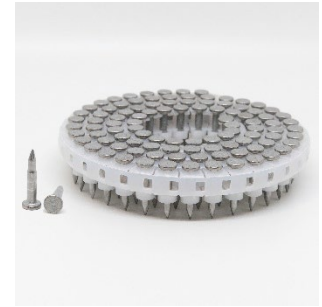
ICC-ES Evaluation Reports are not to be construed as representing aesthetics or any other attributes not specifically addressed, nor are they to be construed as an endorsement of the subject of the report or a recommendation for its use. There is no warranty by ICC Evaluation Service, LLC, express or implied, as to any finding or other matter in this report, or as to any product covered by the report.



Copyright © 2025 ICC Evaluation Service, LLC. All rights reserved.

<p>DIVISION: 03 00 00— CONCRETE</p> <p>Section: 03 16 00— Concrete Anchors</p> <p>DIVISION: 04 00 00— MASONRY</p> <p>Section: 04 05 19.16— Masonry Anchors</p> <p>DIVISION: 05 00 00— METALS</p> <p>Section: 05 05 23— Metal Fastenings</p> <p>DIVISION: 09 00 00— FINISHES</p> <p>Section: 09 22 16.23— Fasteners</p>	<p>REPORT HOLDER: AEROSMITH FASTENING SYSTEMS</p> 	<p>EVALUATION SUBJECT: AEROSMITH 3000 SERIES FASTENERS</p>	
--	--	---	---

1.0 EVALUATION SCOPE

Compliance with the following codes:

- 2021, 2018, 2015 and 2012 [International Building Code® \(IBC\)](#)
- 2021, 2018, 2015 and 2012 [International Residential Code® \(IRC\)](#)

Property evaluated:

Structural

2.0 USES

Aerosmith 3000 Series power-driven fasteners are power-actuated-fasteners used to fasten building components such as light-gage cold-formed steel framing to normalweight concrete, sand-lightweight concrete, sand-lightweight concrete filled steel deck panels, concrete masonry units (CMUs) and structural steel substrate materials. The fasteners are used as alternatives to the cast-in-place concrete anchors described in IBC Section 1901.3 (2012 IBC Section 1908) for placement in concrete; the embedded anchors described in Section 8.1.3 of TMS 402, referenced in Section 2107 of the IBC (Section 2.1.4 of TMS 402-11, referenced in Section 2107 of the 2012 IBC) for placement in masonry; and to the welds and bolts used to attach to steel, described in IBC Sections 2204.1 and 2204.2. For structures regulated under the IRC, the fasteners may also be used where an engineered design is submitted in accordance with IRC Section R301.1.3.

3.0 DESCRIPTION

3.1 Aerosmith 3000 Series Power Driven Fasteners:

Aerosmith 3000 Series power-driven fasteners are manufactured from steel complying with ASTM A510, Grade 1060, and austempered to a Rockwell “C” 52 to 56 core hardness. See [Table 1](#) for shank descriptions, fastener dimensions, coating information and applicable base materials. See [Figure 1](#) for fastener images.

3.2 Substrate Materials:

3.2.1 Concrete: Normalweight and lightweight concrete must comply with IBC Chapter 19 or IRC Section R402.2, as applicable. The minimum concrete compressive strength at the time of fastener installation must be as noted in the applicable allowable load table.

3.2.2 Steel Deck Panels: Steel deck panels must conform to a code-referenced material standard, with the minimum thickness, minimum yield strength and specified tensile strength noted in [Table 5](#). See [Figures 2](#) and [3](#) for panel configuration requirements.

3.2.3 Concrete Masonry: CMUs must be minimum 8-inch-thick blocks, lightweight blocks conforming to ASTM C90. Mortar must be Type N or Type S in accordance with ASTM C270.

3.2.4 Structural Steel: Structural steel used in supports must comply with the minimum strength requirements of ASTM A36, ASTM A572 Grade 50 or ASTM A992, and must have thicknesses as noted in [Tables 6](#) and [7](#), as applicable.

4.0 DESIGN AND INSTALLATION

4.1 Design:

4.1.1 General: Selection of fasteners must take into consideration the applicable base material and the length of the fastener. The minimum fastener length must be determined as follows:

- Unless otherwise noted, for installation into concrete, concrete-filled steel deck panels, concrete masonry and steel base materials, the minimum effective shank length shown in [Table 1](#) must equal or exceed the sum of the thickness of the attached material and the minimum embedment depth (penetration) shown in the applicable tables in this report.
- For installation through steel base materials, the minimum effective shank length shown in [Table 1](#) must equal or exceed the sum of the following: the thickness of the attached material, the thickness of the base material and the required point penetration shown in the applicable tables in this report.

4.1.2 Allowable Loads: The applicable allowable shear and tension load tables for the fasteners driven into different base materials may be determined by referencing [Table 1](#).

The most critical applied loads, excluding seismic load effects, resulting from the load combinations in Section 2.4 of ASCE 7-16/S1 (referenced in IBC Section 1605.1) or 2021 IBC Section 1605.2 (IBC Section 1605.3.1 or 1605.3.2 of the 2018, 2015 and 2012 IBC) must not exceed the allowable loads described in this section. For fasteners which are subjected to seismic loads, see Section 4.1.5 for additional information.

The allowable shear and tension (pullout) values in the tables of this report are for use in allowable stress design (ASD). The allowable loads apply to the interaction between the fasteners and the specified base materials only, and limit states such as pull-over and lateral bearing, which are governed by the properties of attached materials, are outside the scope of this report. Design of the connection to the attached material must comply with the applicable requirements of the IBC. The stress increases and load reductions described in 2021 IBC Section 1605.2 (2018, 2015 and 2012 IBC Section 1605.3) are not allowed.

4.1.3 Combined Loading: For fasteners subjected to both shear and tension loads, compliance with the following interaction equation must be verified:

$$(p/P_a) + (v/V_a) \leq 1$$

where:

- p = Actual applied tension load on fastener, lbf(N)
- P_a = Allowable tension load for the fastener, lbf (N)
- v = Actual applied shear load on fastener, lbf (N)
- V_a = Allowable shear load for the fastener, lbf (N)

4.1.4 Steel-to-Steel Connections: When the fasteners listed in [Tables 6](#) and [7](#) are used in connections of two steel elements in accordance with Section J5 of AISI S100 (Section E5 of AISI S100-12), connection capacity must be determined in accordance with Sections 4.1.4.1 and 4.1.4.2, as applicable.

4.1.4.1 Connection Strength – Tension: To determine tensile connection strength in accordance with Section J5.2 of AISI S100 (Section E5.2 of AISI S100-12), the fastener tension strength, pull-out strength and pull-over strength must be known. These characters must be determined as follows:

- **PAF Tensile Strength:** The allowable fastener tension strengths must be calculated in accordance with Section J5.2.1 of AISI S100 (Section E5.2.1 of AISI S100-12) using a value of 260,000 psi for F_{uh} .
- **Pull-out Strength:** See [Tables 6](#) or [7](#), as applicable, for available pull-out strength.
- **Pull-over Strength:** The available pull-over strengths must be calculated in accordance with Section J5.2.3 of AISI S100 (Section E5.2.3 of AISI S100-12).

4.1.4.2 Connection Strength – Shear: To determine shear connection strength in accordance with Section J5.3 of AISI S100 (Section E5.3 of AISI S100-12), the fastener shear strength, bearing and tilting strength, pull-out strength in shear, net section rupture strength and shear strength limited by edge distance must be known. These characteristics must be determined as follows:

- **PAF Shear Strength:** The allowable fastener shear strengths must be calculated in accordance with Section J5.3.1 of AISI S100 (Section E.5.3.1 of AISI S100-12) using a value of 260,000 psi for F_{uh} .
- **Bearing and Tilting Strength:** The available bearing and tilting strengths must be calculated in accordance with Section J5.3.2 of AISI S100 (Section E5.3.2 of AISI S100-12).
- **Pull-out Strength in Shear:** The available pull-out strength in shear must be the applicable allowable shear strength from [Table 6](#) or [7](#), as applicable, or must be calculated in accordance with Section J5.3.3 of AISI S100 (Section E5.3.3 of AISI S100-12).
- **Net Section Rupture Strength and Shear Strength Limited by Edge Distance:** The net section rupture strength must be determined in accordance with Section J5.3.4 of AISI S100 (Section E5.3.4 of AISI S100-12) and the shear strength limited by edge distance must be determined in accordance with Section J5.3.5 of AISI S100 (Section E5.3.5 of AISI S100-12).

4.1.5 Seismic Considerations: The fasteners are recognized for use when subjected to seismic loads as follows:

1. The fasteners may be used for attachment of nonstructural components listed in Section 13.1.4 of ASCE 7, which are exempt from the requirements of ASCE 7.
2. Concrete Base Materials: The fasteners installed in concrete base materials may be used to support acoustical tile or lay-in panel suspended ceiling systems, distributed systems and distribution systems where the service load on any individual fastener does not exceed the lesser of 90 lbf (400 N) or the published allowable load shown in [Tables 2](#), [3](#) and [5](#), as applicable.
3. Steel Base Materials: The fasteners installed in steel may be used for attaching nonstructural components where the service load on any individual fastener does not exceed the lesser of 250 lbf (1112 N) or the published allowable load shown in [Tables 6](#) and [7](#), as applicable.
4. Interior, Nonstructural Walls: For interior, nonstructural walls that are not subject to sustained tension loads and are not a bracing application, the power-driven fasteners described in Section 3.0 may be used to attach steel track to concrete or steel in all Seismic Design Categories. In Seismic Design Categories D, E and F, the allowable shear load due to transverse pressure must be no more than 90 pounds (400 N) when attaching to concrete; or 250 pounds (1,112 N) when attaching to steel. Substantiating calculations are submitted addressing the fastener-to-base-material capacity and the fastener-to-attached-material capacity. Interior nonstructural walls are limited to locations where bearing walls, shear walls or braced walls are not required by the approved plans. The design load on the fastener must not exceed the allowable load shown in [Tables 2](#), [3](#), [5](#), [6](#) and [7](#), as applicable.

4.2 Installation:

4.2.1 General: The fasteners must be installed in accordance with this report and the Aerosmith Fastening Systems published installation instructions. A copy of these instructions must be available on the jobsite at all times during installation.

The fasteners are installed with a power fastening tool in accordance with Aerosmith Fastening Systems recommendations. The fastener penetration, spacing and edge distances must be as noted in the tables of this report. For fasteners installed into concrete, the fasteners must not be driven until the concrete has reached the designated compressive strength.

5.0 CONDITIONS OF USE:

The Aerosmith 3000 Series power driven fasteners described in this report comply with, or are suitable alternatives to what is specified in, those codes listed in section 1.0 of this report, subject to the following conditions:

- 5.1 The fasteners must be manufactured and identified in accordance with this report.
- 5.2 Fastener installation must comply with this report and Aerosmith Fastening Systems published installation instructions. In the event of a conflict between this report and the Aerosmith Fastening Systems published installation instructions, this report governs.
- 5.3 Calculations demonstrating that the applied loads are less than the allowable loads described in this report must be submitted to the code official. The calculations must be prepared by a registered design professional where required by the statutes of the jurisdiction in which the project is to be constructed.
- 5.4 Refer to Section 4.1.5 for seismic considerations.
- 5.5 The minimum concrete thickness must be three times the fastener embedment, except where noted otherwise in this report.
- 5.6 The use of fasteners is limited to uncracked concrete or masonry. Cracking occurs when $f_t > f_r$ due to service loads or deformations.
- 5.7 Installation must be limited to dry interior environments, which include exterior walls which are protected by an exterior wall envelope.
- 5.8 The use of fasteners in contact with preservative-treated or fire-retardant-treated wood is outside the scope of this report.
- 5.9 The fasteners are manufactured under a quality control program with inspections by ICC-ES.

6.0 EVIDENCE SUBMITTED

Data in accordance with the [ICC-ES Acceptance Criteria for Power-actuated Fasteners Driven into Concrete, Steel, and Masonry Elements \(AC70\)](#), dated December 2019 (editorially revised January 2021).

7.0 IDENTIFICATION

- 7.1 The containers of the fasteners must be labeled with the manufacturer's name (Aerosmith Fastening Systems); the product name, length catalog number, and quantity; the evaluation report number (ESR-3833); and the manufacturing date. In addition, all the fasteners are identified by the logo symbol stamped into the fastener head as shown in [Figure 1](#).
- 7.2 The report holder's contact information is the following:

AEROSMITH FASTENING SYSTEMS
5621 DIVIDEND ROAD
INDIANAPOLIS, INDIANA 46241
(800) 528-8183
www.aerosmithfastening.com
info@aerosmithfastening.com

TABLE 1—AEROSMITH 3000 SERIES FASTENERS

FASTENER ¹	SHANK TYPE	SHANK DIAMETER (inch)	HEAD DIAMETER (inch)	MAXIMUM POINT LENGTH (inch)	MINIMUM EFFECTIVE SHANK LENGTH (inch)	FASTENER COATING	APPLICABLE BASE MATERIAL	APPLICABLE LOAD TABLES
3193HP	Smooth, straight	0.125	0.253	0.230	0.725	Black oxide, Zinc	Concrete	2, 3, 5
							Masonry	4
							Steel	6, 7
3193HPST	Smooth, stepped	0.104/0.125	0.253	n/a	0.725	Zinc	Concrete	2, 5

For SI: 1 inch = 25.4 mm.

TABLE 2—ALLOWABLE TENSION AND SHEAR VALUES FOR AEROSMITH 3000 SERIES FASTENERS INSTALLED IN NORMAL-WEIGHT CONCRETE (lbf)

SHANK TYPE	NOMINAL SHANK DIAMETER (inch)	MINIMUM EDGE DISTANCE (inches)	MINIMUM SPACING (inches)	MINIMUM EMBEDMENT DEPTH (inch)	ALLOWABLE LOADS (lbf)					
					Concrete Compressive Strength:		2,500 psi		4,000 psi	
Load Direction:					Tension	Shear	Tension	Shear	Tension	Shear
Straight	0.125	3.2	4.0	$\frac{5}{8}$ $\frac{3}{4}$	83 107	109 156	78 104	80 195	95 —	128 —
Stepped	0.104/0.125	3.0	4.0	$\frac{5}{8}$	—	—	102	138	101	119

For **SI**: 1 inch = 25.4 mm, 1 psi = 6.89 kPa, 1 lbf = 4.45 N.

¹The fasteners must not be driven until the concrete has reached the designated minimum compressive strength. Minimum concrete thickness is three times the fastener embedment into the concrete.

TABLE 3—ALLOWABLE TENSION AND SHEAR VALUES FOR AEROSMITH 3000 SERIES FASTENERS INSTALLED IN MINIMUM 3,000 psi SAND-LIGHTWEIGHT CONCRETE (lbf)

SHANK TYPE	NOMINAL SHANK DIAMETER (inch)	MINIMUM SPACING (inches)	MINIMUM EDGE DISTANCE (inches)	MINIMUM EMBEDMENT DEPTH (inch)	ALLOWABLE LOADS (lbf)	
					Tension	Shear
Straight	0.125	4.0	3.2	$\frac{5}{8}$ $\frac{3}{4}$	84 108	108 173
Stepped	0.104/0.125	4.0	3.0	$\frac{5}{8}$	109	181

For **SI**: 1 inch = 25.4 mm, 1 psi = 6.89 kPa, 1 lbf = 4.45 N.

¹The fasteners must not be driven until the concrete has reached the designated minimum compressive strength. Minimum concrete thickness is three times the fastener embedment into the concrete, unless noted otherwise.

TABLE 4—ALLOWABLE TENSION AND SHEAR VALUES FOR AEROSMITH 3000 SERIES FASTENERS INSTALLED IN HOLLOW CONCRETE MASONRY UNITS (CMUs)^{1,2} (lbf)

SHANK TYPE	NOMINAL SHANK DIAMETER (inch)	MINIMUM EDGE DISTANCE (inches)	MINIMUM SPACING (inches)	MINIMUM EMBEDMENT DEPTH (inch)	ALLOWABLE LOADS (lbf)					
					Fastener Location:		Face Shell ¹		Horizontal Mortar Joint (Bed Joint) ²	
Load Direction:					Tension	Shear	Tension		Shear ³	
							Type N ⁴	Type S ⁵	Type N ⁴	Type S ⁵
Straight	0.125	2	4	$\frac{5}{8}$	133	—	14	21	22	33

For **SI**: 1 inch = 25.4 mm, 1 lbf = 4.45 N.

¹Fasteners must be located a minimum of 2 inches from the mortar joints, center web and end web of the CMU.

²Fasteners must not be installed in the head joints. Fasteners installed in the bed joint must be installed a minimum of 8 inches from the end of the wall. Multiple fasteners in a bed joint must be spaced a minimum of 8 inches.

³Value applies to loads both parallel and perpendicular to the bed joint.

⁴Value applies to fasteners installed into Type N mortar.

⁵Value applies to fasteners installed into Type S mortar.

TABLE 5—ALLOWABLE TENSION AND SHEAR VALUES FOR FASTENERS INSTALLED THROUGH METAL DECK INTO MINIMUM 3000 psi SAND-LIGHTWEIGHT CONCRETE¹

SHANK TYPE	NOMINAL SHANK DIAMETER (inch)	MINIMUM SPACING (inches)	MINIMUM EMBEDMENT DEPTH (inch)	ALLOWABLE LOADS (lbf)							
				3-inch deep “W3” type steel deck ²				1½-inch deep “B” type steel deck ³			
Deck Type:				Upper flute		Lower flute		Upper flute		Lower flute	
Fastener Location:				Upper flute		Lower flute		Upper flute		Lower flute	
Load Direction:				Tension	Shear	Tension	Shear	Tension	Shear	Tension	Shear
Straight	0.125	4.0	5/8	—	—	72	242	—	—	—	—
			3/4	—	—	93	288	—	—	—	—
Stepped	0.104/0.125	4.0	5/8	103	221	95	219	101	215	107	224

For SI: 1 inch = 25.4 mm, 1 psi = 6.89 kPa, 1 lbf = 4.45 N.

¹The fasteners must not be driven until the concrete has reached the designated minimum compressive strength. Minimum concrete thickness is three times the fastener embedment into the concrete.

²The steel deck must have a minimum base-metal thickness of 0.035 inch, a minimum yield strength of 38 ksi, and a minimum tensile strength of 52 ksi. Fasteners installed through the lower flutes of the deck must have a minimum edge distance of 1⅛ inches from the edge of the steel deck and 3 inches from the end of the deck. Concrete thickness above the deck must be a minimum of 3½ inches. See [Figure 3](#) of this report.

³The steel deck must have a minimum base-metal thickness of 0.035 inch, a minimum yield strength of 38 ksi, and a minimum tensile strength of 52 ksi. Fasteners installed through the lower flutes of the deck must have a minimum edge distance of 7/8 inches from the edge of the steel deck and 3 inches from the end of the deck. Concrete thickness above the deck must be a minimum of 2¼ inches. See [Figure 2](#) of this report.

TABLE 6—ALLOWABLE TENSION AND SHEAR VALUES FOR AEROSMITH 3000 SERIES FASTENERS INSTALLED IN ASTM A36 STEEL¹ (lbf)

NOMINAL SHANK DIAMETER (inch)	MINIMUM EDGE DISTANCE (inch)	MINIMUM SPACING (inch)	STEEL THICKNESS (inch)					
			3/16		1/4		3/8 ²	
			Tension ³	Shear	Tension ³	Shear	Tension	Shear
0.125	0.5	1.0	63	162	239	211	113	197

For SI: 1 inch = 25.4 mm, 1 lbf = 4.45 N.

¹The allowable tension and shear values are for fastenings that have the point end of the fastener driven through the steel base material, unless otherwise noted.

²Fastener penetration in 3/8 inch steel is a minimum of 0.29 inch.

³For steel-to-steel connections designed in accordance with Section 4.1.4, the tabulated allowable load may be increased by a factor of 1.25, and the design strength may be taken as the tabulated allowable load multiplied by a factor of 2.0.

TABLE 7—ALLOWABLE TENSION AND SHEAR VALUES FOR AEROSMITH 3000 SERIES FASTENERS INSTALLED IN ASTM A572 GRADE 50 OR ASTM A992 STEEL¹ (lbf)

NOMINAL SHANK DIAMETER (inch)	MINIMUM EDGE DISTANCE (inch)	MINIMUM SPACING (inch)	STEEL THICKNESS (inch)					
			3/16		1/4		3/8 ²	
			Tension ³	Shear	Tension ³	Shear	Tension	Shear
0.125	0.5	1.0	103	222	147	119	147	112

For SI: 1 inch = 25.4 mm, 1 lbf = 4.45 N.

¹The allowable tension and shear values are for fastenings that have the pointed end of the fastener driven through the steel base material, unless otherwise noted.

²Fastener penetration in 3/8 inch steel is a minimum of 0.27 inch.

³For steel-to-steel connections designed in accordance with Section 4.1.4, the tabulated allowable load may be increased by a factor of 1.25, and the design strength may be taken as the tabulated allowable load multiplied by a factor of 2.0.

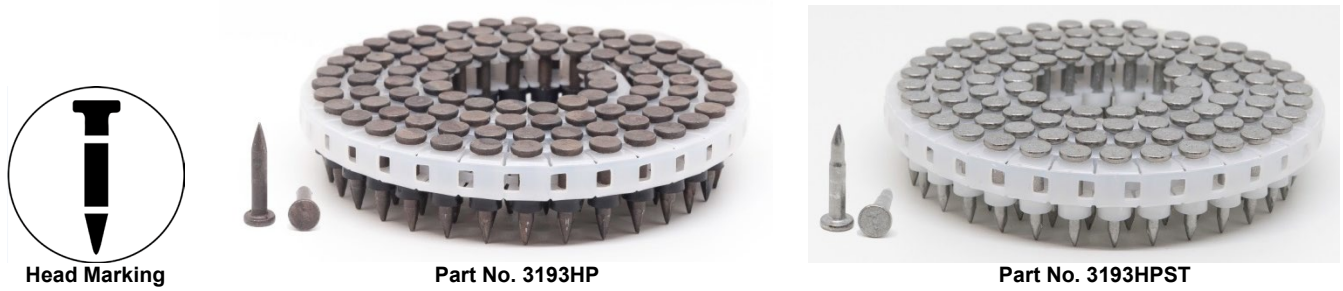

FIGURE 1—AEROSMITH 3000 SERIES FASTENERS

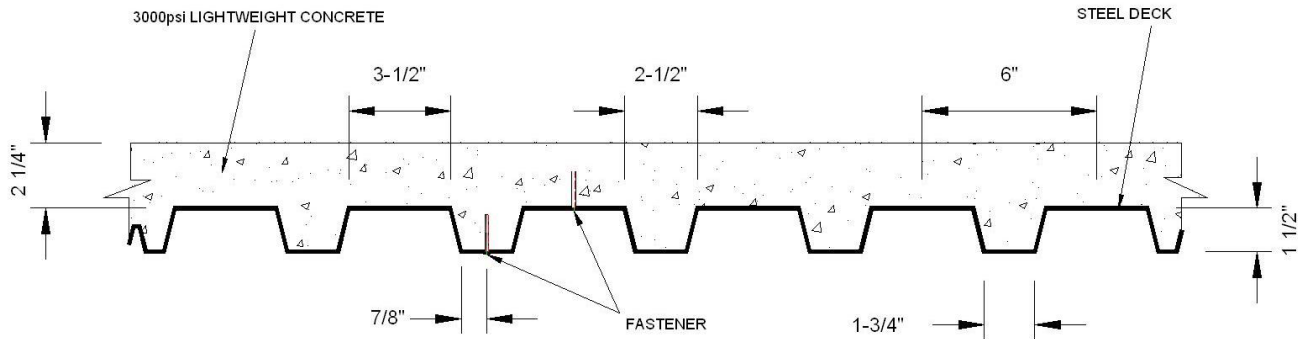

FIGURE 2—FASTENER INSTALLATION SAND-LIGHTWEIGHT CONCRETE FILLED “B” STEEL DECK

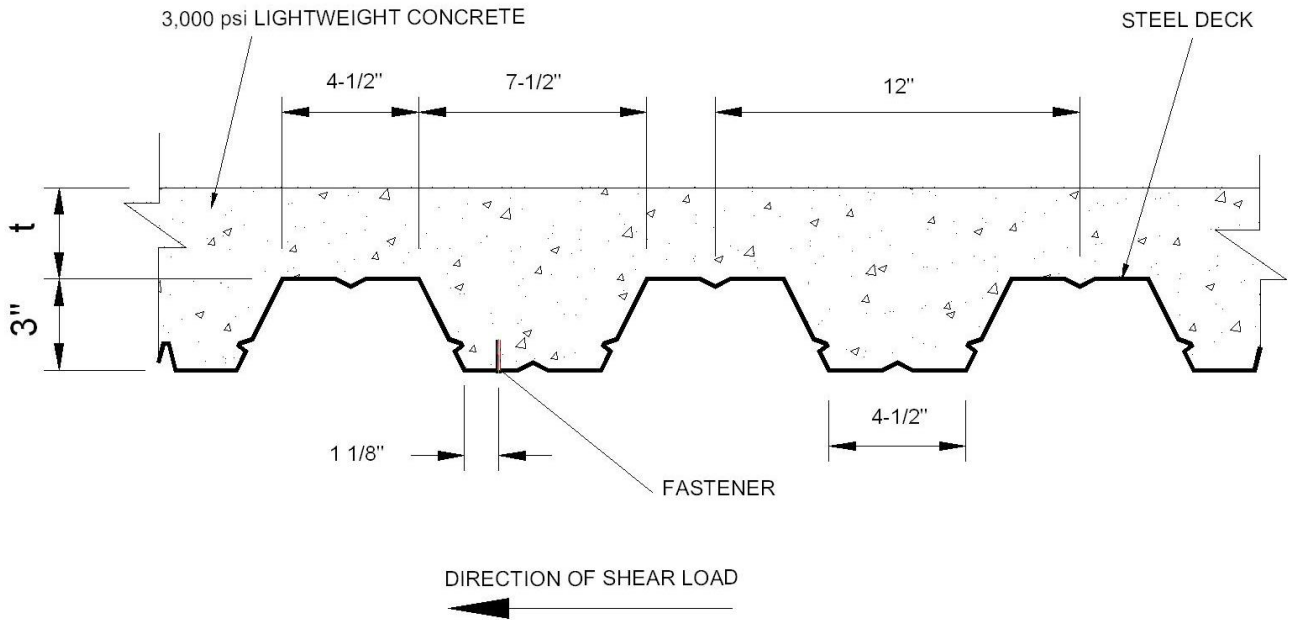

FIGURE 3—FASTENER INSTALLATION SAND-LIGHTWEIGHT CONCRETE FILLED “W3” STEEL DECK

DIVISION: 03 00 00—CONCRETE

Section: 03 16 00—Concrete Anchors

DIVISION: 04 00 00—MASONRY

Section: 04 05 19.16—Masonry Anchors

DIVISION: 05 00 00—METALS

Section: 05 05 23—Metal Fastenings

DIVISION: 09 00 00—FINISHES

Section: 09 22 16.23—Fasteners

REPORT HOLDER:

AEROSMITH FASTENING SYSTEMS

EVALUATION SUBJECT:

AEROSMITH 3000 SERIES FASTENERS

1.0 REPORT PURPOSE AND SCOPE

Purpose:

The purpose of this evaluation report supplement is to indicate that Aerosmith 3000 Series fasteners, described in ICC-ES evaluation report [ESR-3833](#), have also been evaluated for compliance with the codes noted below as adopted by the Los Angeles Department of Building and Safety (LADBS).

Applicable code editions:

- 2020 City of Los Angeles Building Code ([LABC](#))
- 2020 City of Los Angeles Residential Code ([LARC](#))

2.0 CONCLUSIONS

The Aerosmith 3000 Series fasteners, described in Sections 2.0 through 7.0 of the evaluation report [ESR-3833](#), comply with the LABC Chapters 19, 21 and 22 and the LARC, and are subject to the conditions of use described in this supplement.

3.0 CONDITIONS OF USE

The Aerosmith 3000 Series fasteners described in this evaluation report supplement must comply with all of the following conditions:

- All applicable sections in the evaluation report [ESR-3833](#).
- The design, installation, conditions of use and identification of the Aerosmith 3000 Series fasteners are in accordance with the 2018 *International Building Code*® (IBC) provisions noted in the evaluation report [ESR-3833](#).
- The design and inspection are in accordance with additional requirements of LABC Chapters 16 and 17, as applicable.
- For seismic applications, the Aerosmith fasteners must comply with Section 4.1.5 of the evaluation report [ESR-3833](#).
- Under the LARC, an engineered design in accordance with LARC Section R301.1.3 must be submitted.
- The allowable load values listed in the evaluation report and tables are for the connection of the fasteners to normalweight concrete, lightweight concrete, lightweight concrete over metal decks, concrete masonry and steel. The connection between the fasteners and the connected members must be checked for capacity (which may govern).

This supplement expires concurrently with the evaluation report, reissued August 2025.

DIVISION: 03 00 00—CONCRETE

Section: 03 16 00—Concrete Anchors

DIVISION: 04 00 00—MASONRY

Section: 04 05 19.16—Masonry Anchors

DIVISION: 05 00 00—METALS

Section: 05 05 23—Metal Fastenings

DIVISION: 09 00 00—FINISHES

Section: 09 22 16.23—Fasteners

REPORT HOLDER:

AEROSMITH FASTENING SYSTEMS

EVALUATION SUBJECT:

AEROSMITH 3000 SERIES FASTENERS

1.0 REPORT PURPOSE AND SCOPE**Purpose:**

The purpose of this evaluation report supplement is to indicate that Aerosmith 3000 Series Fasteners, described in ICC-ES evaluation report [ESR-3833](#), have also been evaluated for compliance with the codes noted below.

Applicable code editions:

- 2022 and 2019 *California Building Code* (CBC)

For evaluation of applicable chapters adopted by the California Office of Statewide Health Planning and Development (OSHPD) AKA: California Department of Health Care Access and Information (HCAI) and Division of State Architect (DSA), see Sections 2.1.1 and 2.1.2 below.

- 2022 and 2019 *California Residential Code* (CRC)

2.0 CONCLUSIONS**2.1 CBC:**

The Aerosmith 3000 Series Fasteners, described in Sections 2.0 through 7.0 of the evaluation report [ESR-3833](#), comply with CBC Chapters 19, 21 and 22, provided the design and installation are in accordance with the 2021 and 2018 *International Building Code*® (IBC) provisions, as applicable, noted in the evaluation report and the additional requirements of CBC Chapters 16, 17, 19, 21 and 22, as applicable.

2.1.1 OSHPD:

The Aerosmith 3000 Series Fasteners, described in Sections 2.0 through 7.0 of the evaluation report [ESR-3833](#), comply with CBC amended Chapter 19 [OSHPD 1R, 2 & 5], and Chapter 19A [OSHPD 1 & 4], provided the design and installation are in accordance with the 2021 and 2018 *International Building Code*® (IBC) provisions, as applicable, noted in the evaluation report and the additional requirements in Sections 2.1.1.1 and 2.1.1.2 of this supplement:

2.1.1.1 Verification Test Requirements: The installation verification test loads, frequency, and acceptance criteria shall be in accordance with Section 1901.3.4 [OSHPD 1R, 2B & 5] or 1910A.5 [OSHPD 1 & 4] of the 2022 CBC or Section 1901.3.4 [OSHPD 1R, 2 & 5] or 1910A.5 [OSHPD 1 & 4] of the 2019 CBC, as applicable.

2.1.1.2 Conditions of Use: Power actuated fasteners in seismic shear applications shall be in accordance with Section 1901.3.1 [OSHPD 1R, 2 & 5] or Section 1617A.1.20 [OSHPD 1 & 4].

2.1.2 DSA:

The Aerosmith 3000 Series Fasteners, described in Sections 2.0 through 7.0 of the evaluation report [ESR-3833](#), comply with CBC amended Chapter 19 [DSA-SS/CC] and Chapter 19A [DSA-SS], provided the design and installation are in accordance with the 2021 and 2018 *International Building Code*[®] (IBC) provisions, as applicable, noted in the evaluation report and the additional requirements in Sections 2.1.2.1 and 2.1.2.2 of this supplement:

2.1.2.1 Verification Test Requirements: The installation verification test loads, frequency, and acceptance criteria shall be in accordance with Section 1909.2.7 [DSA-SS/CC] or 1910A.5 [DSA-SS] of the CBC, as applicable.

2.1.2.2 Conditions of Use: Power actuated fastener in seismic shear application shall be in accordance with Section 1617A.1.20 [DSA-SS].

2.2 CRC:

The Aerosmith 3000 Series Fasteners, described in Sections 2.0 through 7.0 of the evaluation report [ESR-3833](#), comply with the CRC, provided the design and installation are in accordance with the 2021 and 2018 *International Residential Code*[®] (IRC) provisions, as applicable, noted in the evaluation report.

This supplement expires concurrently with the evaluation report, reissued August 2025.