



# Shibuya Hoppmann

## Model FS-30-RD Centrifugal Feeders

### *ANSI/Metric Installation & Maintenance Manual*

***Refer all servicing to  
qualified personnel.***

*This manual is written for  
qualified mechanics and  
electricians who must  
install or service the  
FS-30-RD Feeder.*



*Please copy this information  
from the FS-30-RD  
Feeder's serial plate.*

Model Number:

Serial Number/Date:

Inventory Number (Check One):

- FS301RLDSA       FS301RLASA
- FS301RLDSM     FS301RLASM



First Edition, Revision 1, All Rights Reserved  
Copyright © 2007 by Shibuya Hoppmann Corporation.

13129 Airpark Drive, Suite 120  
Elkwood, Virginia 22718

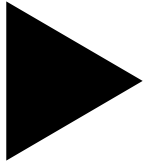
**Phone:** (540) 829-2564  
**Toll Free:** (800) 368-3582

**Fax:** (540) 829-1724

www.hoppmann.com • email: publications@hoppmann.com



# Quick Start



## About this Manual

### Assumptions

This manual is written for a qualified mechanic or electrician who must install or service the FS-30-RD Centrifugal Feeder. All procedures in this manual should be performed by qualified personnel or under their direction.

► Some references in this manual may not apply to your feeder. In specific cases, your direct supplier may have modified or replaced some of the standard components of your feeder on which these procedures are based. In such cases, you may need to slightly modify these procedures. If you are unsure which standard components of your FS-30-RD feeder (if any) have been changed, consult your direct supplier's documentation.

### Models Covered

This manual covers 4 models. If you are unsure which model you have, locate the inventory number on the serial plate of the feeder.

<i>Inventory No.</i>	<i>ANSI, SS</i>	<i>Inventory No.</i>	<i>Metric, SS</i>
FS301RLDSA .....	1 DC Motor	FS301RLDSM .....	1 DC Motor
FS301RLASA .....	1 AC Motor	FS301RLASM .....	1 AC Motor

### Caution Symbols & Messages

Caution symbols and messages in this manual call attention to hazardous voltages, moving parts and other hazardous conditions.



The exclamation point caution symbol denotes possible personal injury and/or damage to the equipment.



The lightning bolt caution symbol denotes possible personal injury and/or damage to the equipment from electrical hazards.

### Equipment Improvements & Document Revisions Notice

Shibuya Hoppmann continually improves its products, and reserves the right to change or discontinue specifications and designs shown in this manual without notice and without incurring obligation. Shibuya Hoppmann has made every effort to verify the information contained in this manual, but reserves the right to correct any error at the time of the manual's next revision.

11/05



## ***What to Do First***

**As-Built Documentation** This manual **does not** contain as-built documentation. If you purchased your tooled FS-30-RD feeder directly from Shibuya Hoppmann Corporation, you will automatically receive this information in your system operations manual.

**Tools You Will Need** The FS-30-RD feeders are offered in both ANSI and metric versions. For maximum compatibility, ANSI units are classified as "soft ANSI" construction, meaning that metric threads and hardware are used throughout. Both metric and ANSI units require metric tools for repair or adjustment.

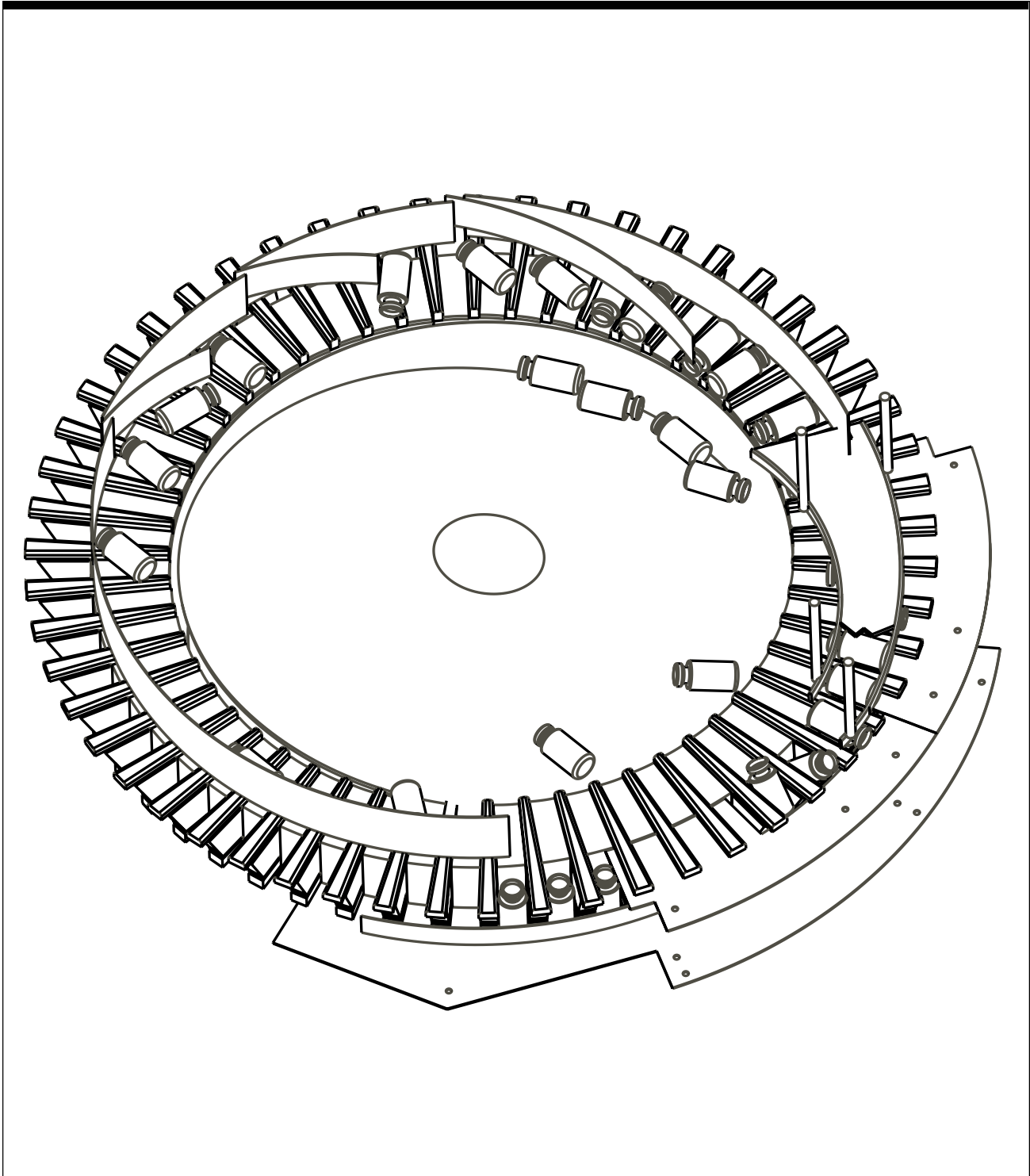
*Note:* Any part of the FS-30-RD feeder that touches your product has been precision tooled to specifically match your product. Do not move tooling or change any settings on the FS-30-RD feeder except as described in this manual, or you may void your warranty and negatively affect the performance of your FS-30-RD Feeder.



# Table of Contents

	Page		Chapter
<b>Quick Start</b>	2	About this Manual	
	3	What to Do First	
<b>Feeder Description &amp; Specifications</b>	7	The FS-30-RD Feeder: An Overview	<b>1</b>
		<i>Figures:</i>	
	6	Figure 1-1. FS-30 Overview of Scallops and Product in Bowl	
	7	Figure 1-2. Product in Scallops and Height Qualifier	
	7	Figure 1-3. Correct Orientation, Exiting Feeder	
	8	Figure 1-4. FS-30-RD Feeder Specifications	
<b>Safety Precautions</b>	9	Safety Precautions	<b>2</b>
	9	Operating & Maintenance: Do's & Don'ts	
<b>Installation &amp; Startup</b>	11	Unpacking, Inspection & Registration	<b>3</b>
	11	Physical Setup	
	12	Starting the Feeder for the First Time	
	13	How to Set Proper Bowl Speed	
	14	Running Product for the First Time	
	14	General Tips	
		<i>Figures:</i>	
	13	Figure 3-1. Measuring & Changing Bowl Speed	
	15	Figure 3-2. DC ANSI Motor Suggested Wiring Diagram	
	16	Figure 3-3. AC ANSI Motor Suggested Wiring Diagram	
	17	Figure 3-4. AC Metric Motor Suggested Wiring Diagram	
	18	Figure 3-5. DC Metric Motor Suggested Wiring Diagram	
<b>Preventive Maintenance</b>	19	General Cleaning	<b>4</b>
	19	Change Gear Motor Oil	
	19	Reducer Lubrication	
	19	Lubricate Chains and Sprockets	
	20	Inspect Chain Tension	
	20	Idler Assembly Maintenance	
	22	Inspect/Replace Motor Brushes	
	23	Lubricate Clutch Assembly	

	Page		Chapter	
		<b>Figures:</b>		
	20	Figure 4-1. Idler Assembly		
	21	Figure 4-2. FS-30-RD Drive Train		
	22	Figure 4-3. Motor Brushes		
	23	Figure 4-4. FS-30-RD Typical Clutch Assembly		
<b>Repair &amp; Troubleshooting</b>	25	Replacing or Refinishing a Damaged Bowl	<b>5</b>	
	26	How to Set Bowl Runout		
	27	Speed Reducer Replacement		
	28	Chain Drive Nomenclature - Single Drive		
	29	Air Clutch Assembly: Adjustment and Replacement		
	32	Idler Assembly Component Replacement		
	32	Major Bearing Replacement		
	35	If Product Jam: General Tips		
		<b>Figures:</b>		
	25	Figure 5-1. Side View - Bowl Mounting		
	28	Figure 5-2. Single Drive Sprocket Location Diagram		
	30	Figure 5-3. FS-30-RD Air Clutch and Motor Assembly		
	31	Figure 5-4. Idler Assembly and Drive Tensioner Assembly		
	33	Figure 5-5. FS-30-RD Spindle Assembly		
	34	Figure 5-6. FS-30-RD Sectional Spindle Assembly Views		
	36	Figure 5-7. FS-30-RD Feeder Troubleshooting		
	37	Figure 5-8. FS-30-RD Feeder Troubleshooting (continued)		
<b>Spare Parts</b>	39	Notice to Hoppmann Customers	<b>6</b>	
	39	Notice to Dealer & OEM Customers		
	39	In North America		
	39	In Europe		
	40	FS-30-RD Standard Recommended Spares		
	41	FS-30-RD Critical Recommended Spares - ANSI		
	41	FS-30-RD Critical Recommended Spares - Metric		
	44	Warranty		



**Figure 1-1. FS-30 Overview of Scallops and Product in Feeder Bowl**

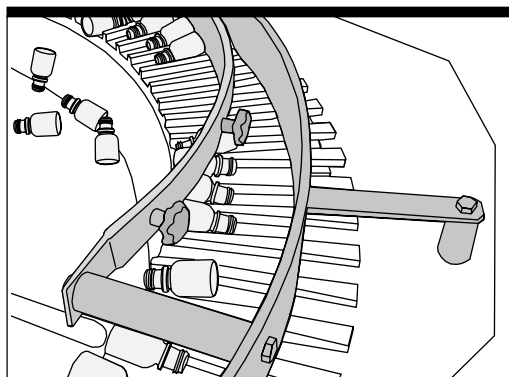
# Feeder Description & Specifications

## 1

### *The FS-30-RD Feeder: An Overview*

**Function** The FS-30-RD feeders unscramble, feed and orient product. The output rate will vary depending on your particular product's characteristics and your desired production speed.

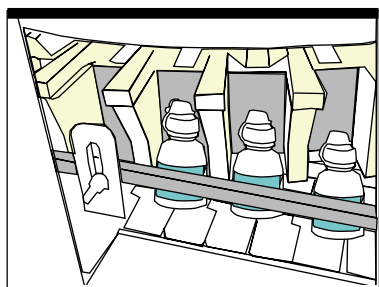
**Operation** **Step 1—The FS-30-RD Feeder Accepts Your Product.** The FS-30-RD feeder accepts product from a separate bulk supply hopper or prefeeder. Product drops randomly, a few at a time, onto a rigid disc. Unlike vibratory feeders, the FS-30-RD feeders run best when product is not emptied in bulk directly onto the rigid disc, but instead, when product is carefully metered into the feeder bowl, a few at a time. The FS-30-RD feeders delivers product almost immediately.



**Figure 1-2. Product in Scallops and Height Qualifier**

**Step 2—The FS-30-RD Feeder Loads and Qualifies Your Product.** After dropping onto the rigid disc, product loads quickly onto the rim of a rotating bowl and are positioned into the scallops (see Figure 1-2). While positioned in the scallops, the product moves past mechanical (height qualifiers), pneumatic and/or optical qualifiers which reject product that are not properly oriented. Improperly oriented product is returned to the bowl and recirculated.

**Step 3—The FS-30-RD Feeder Delivers Your Product.** After the product has been properly qualified, it is guided to the drop zone where the product is dropped vertically, with the assistance of gravity, and thereby placed in the proper orientation (see Figure 1-3). Finally, the product moves out of the FS-30-RD feeder in a rapidly moving and randomly spaced stream by means of a discharge inline system.



**Figure 1-3. Correct Orientation, Exiting Feeder**



# FS-30-RD Feeder Installation/Maintenance Manual

### Standard Models:

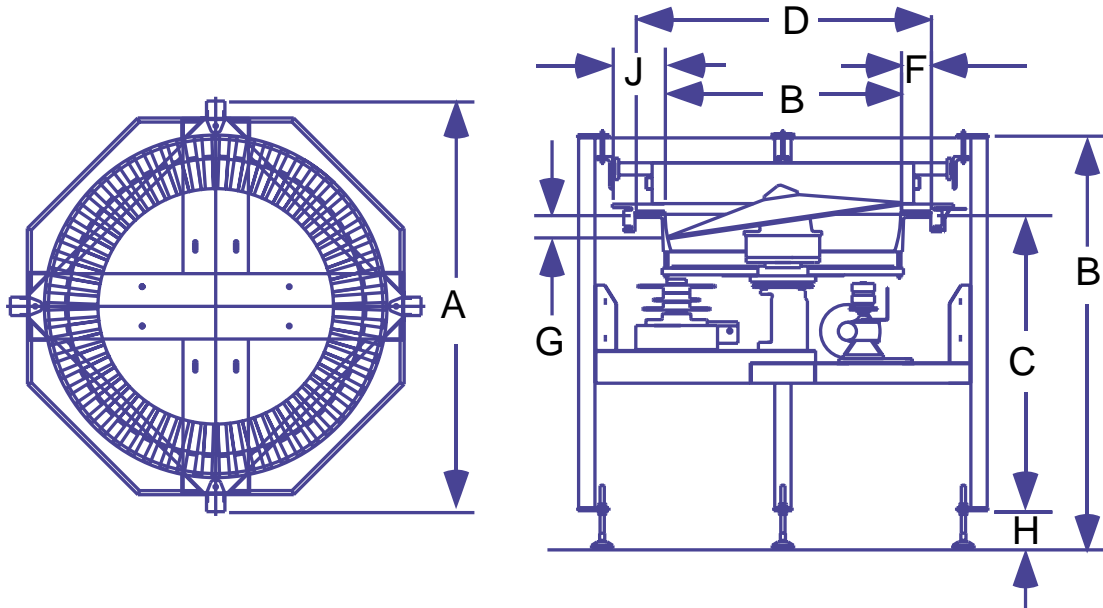
Part Number	<u>FS301RLDSA</u>	<u>FS301RLDSM</u>	<u>FS301RLASA</u>	<u>FS301RLASM</u>
Motor Style	DC	DC	AC	AC
Motor Voltage	90V	180V	230/460V	220/380 50Hz
Horsepower	1/3 hp	250W	1/3 hp	250W

### Product Specifications:

	<u>ANSI</u>	<u>Metric</u>
A. Overall Outside Square	50.25"	1276mm
B. Frame Height	46"	1168mm
C. Bowl Height	36.25"	921mm
D. Bowl Outside Diameter	36.12"	917mm
E. Bowl Inside Diameter	28.80"	732mm
F. Rim Width	3.66"	93mm
G. Bowl Depth	3.98"	101mm
H. Level Foot Adjustment	4.63" ± 2"	118mm ± 51mm

### Required Accessories:

FS Series Scallop Kit ..... FS30SCALXX  
 (includes segment plates and one of the following number of scallops: 36, 48, 54, 60, or 72).



**Your direct supplier may have changed some of these specifications during tooling to better match your application's requirements.**

**Figure 1-4. FS-30-RD Feeder Specifications**



# Safety Precautions

## 2

### *Safety Precautions*



**Turn Off Power!** Before servicing, make sure you have turned off compressed air and electrical power in a way which prevents accidental reactivation. Padlock and clearly tag the appropriate electrical and pneumatic disconnects. Lockout/tagout procedures are covered in United States Code of Federal Regulation (CFR) Title 29 Part 1910.147, "The Control of Hazardous Energy."



**Dress Appropriately!** Reduce the risk of injury from moving parts by securing loose sleeves and other clothing. Do not wear loose jewelry or neckties near the feeder. Wear safety glasses or other protective eyewear when servicing the feeder. Never place hands or tools in the feeder when it is operating.



**Install Safety Covers!** Make sure the feeder remains safe to operate. Be sure all safety covers have been installed before returning the feeder to normal operation. Safety covers on the FS-30-RD Feeder include any covers installed by your direct supplier, as well as the outer frame covers and lexan top covers (which protect the operator from the moving bowl spider, sprockets and chains).

### *Operating & Maintenance: Do's & Don'ts*

**Don't Give the Feeder Too Much Product.** Do not overload the feeder, because it may jam or lose rate. Product must be carefully metered into the feeder from bulk. Allow only enough product into the feeder to keep the line running at the required rate.

**Don't Run the Feeder Too Fast.** Do not run the bowl faster than the linear feet per minute recommended by your direct supplier. If you do, the orientation qualifiers cannot function as efficiently, and the feeder may jam or lose rate.



**Don't Adjust Air Jet Flow Controls.** It is okay to adjust the main air regulator to its correct setting for your installation. However, air jets and their individual flow controls have all been carefully preset to work with your product; they should never need adjustment. If you move air jets or adjust their individual flow controls, the feeder may jam or lose rate.

**Do Perform Preventive Maintenance.** To keep the feeder running without unexpected repairs and resulting "down" time, regularly perform the preventive maintenance procedures in Chapter 4.



**Do Carefully Replace Any Tooling You Remove.** To gain access for repairs, you may need to remove tooling. Because Hoppmann and your dealer /OEM have no control over such activities, they cannot be responsible for any tooling you remove. **Carefully document the position of any tooling before you begin.** If you fail to replace all tooling exactly as it was, you may create difficult and time consuming problems for yourself.

**Don't Take Apart the Spindle Assembly.** Do not take apart the spindle assembly except to replace a failed bearing. If you must replace a bearing, follow the procedures in Chapter 5.

**Don't Install the Feeder Near Flammable Gas, Vapor or Dust.** Do not install a feeder in these conditions unless you install additional, approved explosion-proof or dust ignition-proof enclosures. Without such additional enclosures, normal sparking of the brushes inside the motor could ignite flammable gas, vapor or dust.

# Installation & Startup

## 3

### ***Unpacking, Inspection & Registration***

**Step 1 — Inspect and Unpack the Crate.** Remove packing materials from sensors, tooling and moving parts. Make a visual check to be sure parts have not come loose during shipping. If you find any concealed damage, call the shipping carrier and your direct supplier immediately. ***Do not attempt to fix the problem yourself unless told to do so by your direct supplier.***



**Step 2—Record Model and Serial Numbers.** If you have not already done so, record on the front of this manual the feeder's model and serial number.

### ***Physical Setup***

You should refer to as-built drawings (not part of this manual) for electrical, pneumatic and equipment layout specifications.

**Step 1—Position the Feeder.** Place the feeder as shown on the equipment layout drawing provided by your direct supplier.

**Step 2—Level the Feeder.** Adjust the leveling feet so that the feeder is level. Tighten the locknuts on the leveling feet. In some applications, leveling feet are not used because the feeder is connected directly to other framework.

**Step 3—Connect the Output Device.** Check that product can move smoothly from the exit of the feeder to your downstream equipment (deadplate, conveyor, gravity track or powered rollers, for example). Check that product will not jam or lose their orientation as they move to the output device.

**Step 4—Position the Prefeeder.** Now place your bulk supply hopper, or prefeeder, into position. Follow the equipment layout drawing provided by your direct supplier. *If you are providing and integrating a prefeeder, continue reading. If your direct supplier is providing and integrating both your feeder and prefeeder, skip to Step 5.*

*Continued* ►



**If you are supplying your own prefeeder, you are responsible for:**

- ▶ Providing and installing the feeder's bowl-level switch so it can control the flow of product from your prefeeder.
- ▶ Setting the timing delay for the feeder's bowl-level switch.
- ▶ Correctly positioning the prefeeder. Generally, the prefeeder must discharge product to fall on the highest side of the feeder's rigid disc; this is normally halfway between its center and its outside diameter. Take a handful of product and drop them from the snout of your prefeeder into the feeder. Avoid product bouncing up off the rigid disc into the scallops, this could disturb product that are already loaded. Reposition the prefeeder until product lands correctly.

**Step 5—Connect Power and Air.** Connect your feeder to power and compressed air (if applicable). Do not change the feeder's main air regulator; it should already be correct when you receive the feeder.

## ***Starting the Feeder for the First Time***

**Step 1—Secure Safety Covers and Clothes.** Before turning on power and air, make sure safety covers are in place and that you are dressed appropriately for safety.

**Step 2—Turn on Power and Air.** Turn on the feeder's power. If applicable, turn on the feeder's main air regulator.

**Step 3—Check for Rubbing Parts.** Run the prefeeder, feeder and output device without product. In the unlikely event that you hear squeaks and squeals (there should be none), shut down immediately and check for any remaining packing.

## How to Set Proper Bowl Speed

Ask your direct supplier for the actual linear feet per minute at which the bowl should rotate. For reliability, set the bowl to match that speed.

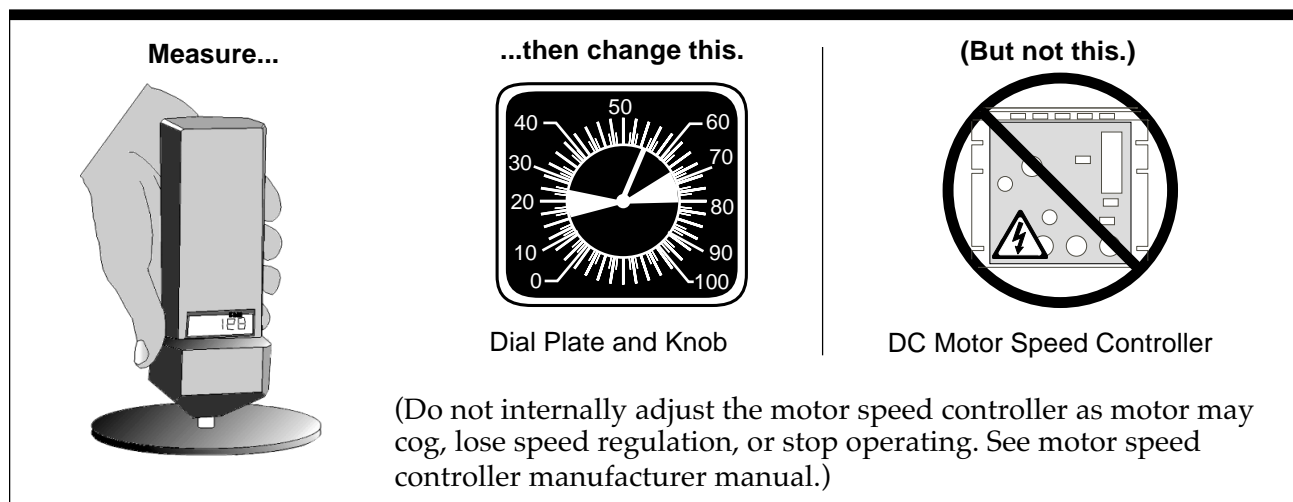
- ▶ You will need a hand-held tachometer (analog or digital) with a surface speed wheel indicator (see Figure 3-1).
- ▶ This procedure is performed with power on and the feeder operating. If your direct supplier has installed a cover over the bowl, you will need to open it before proceeding.

**Step 1—Turn on Feeder.** Turn on the feeder and run it without product.

**Step 2—Set Bowl Speed.** To set bowl speed, place hand-held tachometer (with surface speed indicator attachment) on the inner wall of the moving bowl, at its most upper inside diameter. Adjust bowl speed until bowl is moving at correct number of linear feet per minute (FPM).

- ▶ If you have only one drive motor installed (standard) you can ignore the rigid disc speed, which changes proportionally as the bowl speed changes.

**Step 3—Record New Settings.** Turn off the feeder. Mark dial plate with new setting and remove any old marks.



**Figure 3-1. Measuring and Changing Bowl Speed (DC Motors Only)**



## ***Running Product for the First Time***

**Step 1—Verify Changeover Setup.** If your feeder is tooled to run multiple product, ensure the feeder is set up for the product you want to run.

**Step 2—Inspect Product at Exit.** Inspect the exit of the feeder. If product is exiting the feeder properly oriented, at the required rate and without jamming, then installation is complete. Otherwise, continue with step 3. Do not adjust the flow controls on any air jet.

**Step 3—Verify Prefeeder Speed.** Normally this step is completed by your direct supplier. However, if you are separately providing and integrating the prefeeder, you will have to set the prefeeder's speed. To do this, turn the prefeeder's speed control all the way down, then turn on the feeder.

▶ Slowly (you may need to take several minutes) raise the prefeeder's speed control until enough product exits the feeder to keep the line running at the required rate.

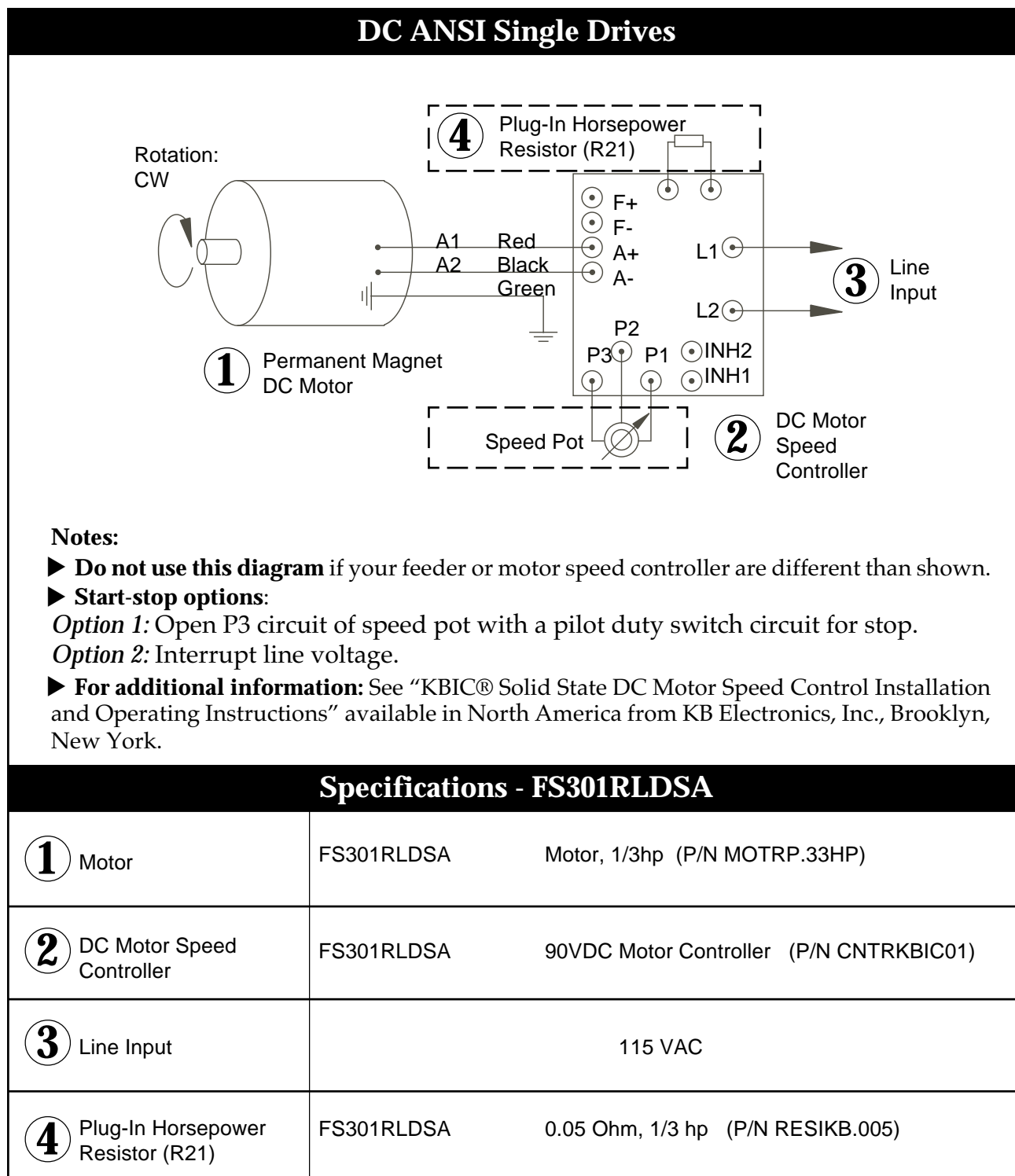
▶ Stop raising the prefeeder speed when enough product is exiting the feeder. ***If you don't stop raising the prefeeder speed, you will overload the feeder and reduce its output.***



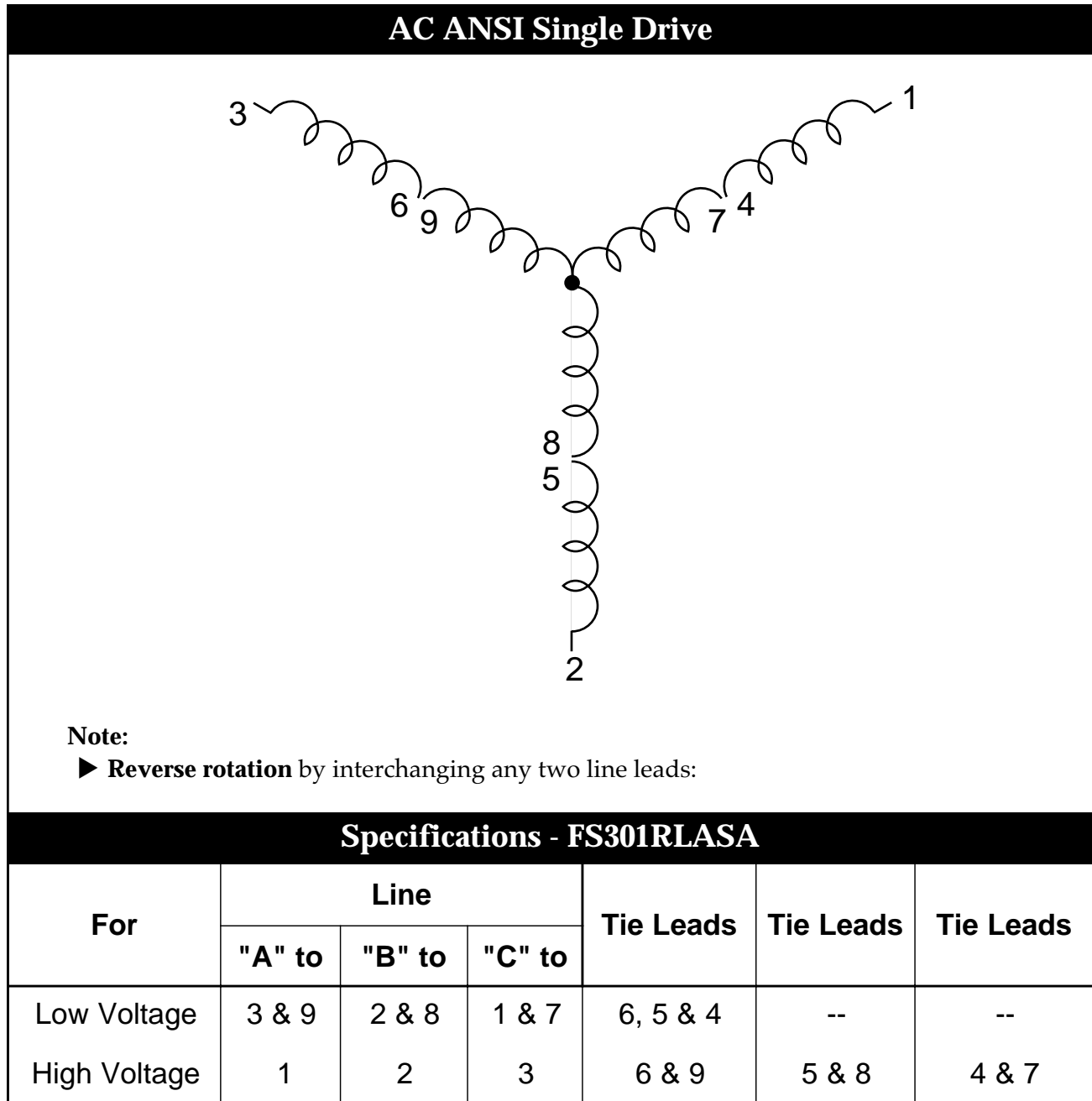
## ***General Tips***

▶ After your feeder is set up and running, observe the flow of product at each transition point. Later, if a problem occurs, observe these transition points to help pinpoint the cause.

▶ Listen to the way the feeder sounds when it is running properly. If it suddenly sounds different, investigate why.

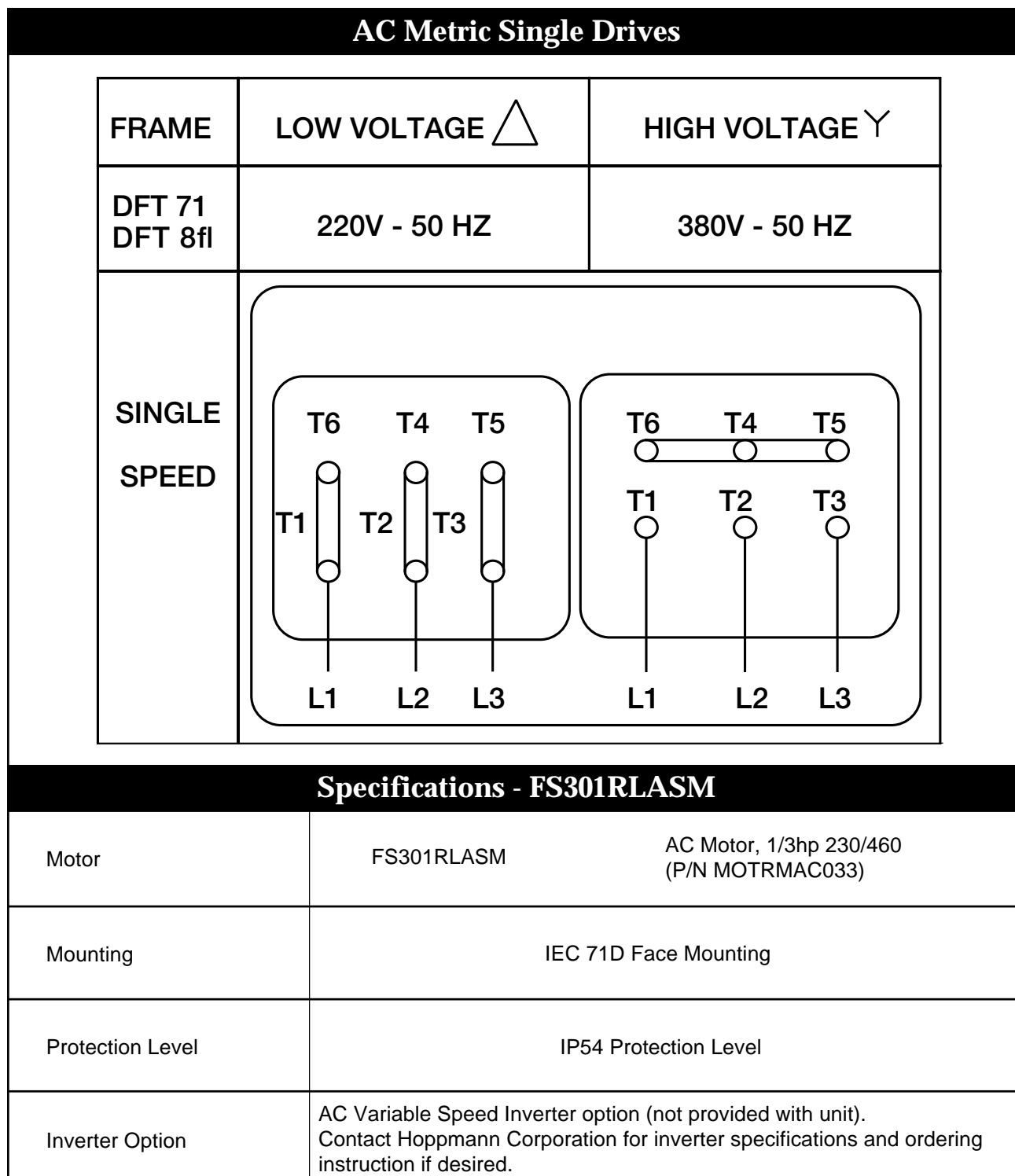


**Figure 3-2. DC ANSI Suggested Wiring Diagram (FS-30-RD Single DC Motor)**



**Figure 3-3. AC ANSI Suggested Wiring Diagram (FS-30-RD Single AC Motor)**





**Figure 3-4. AC Metric Wiring Diagram (FS-30-RD Single Drives)**

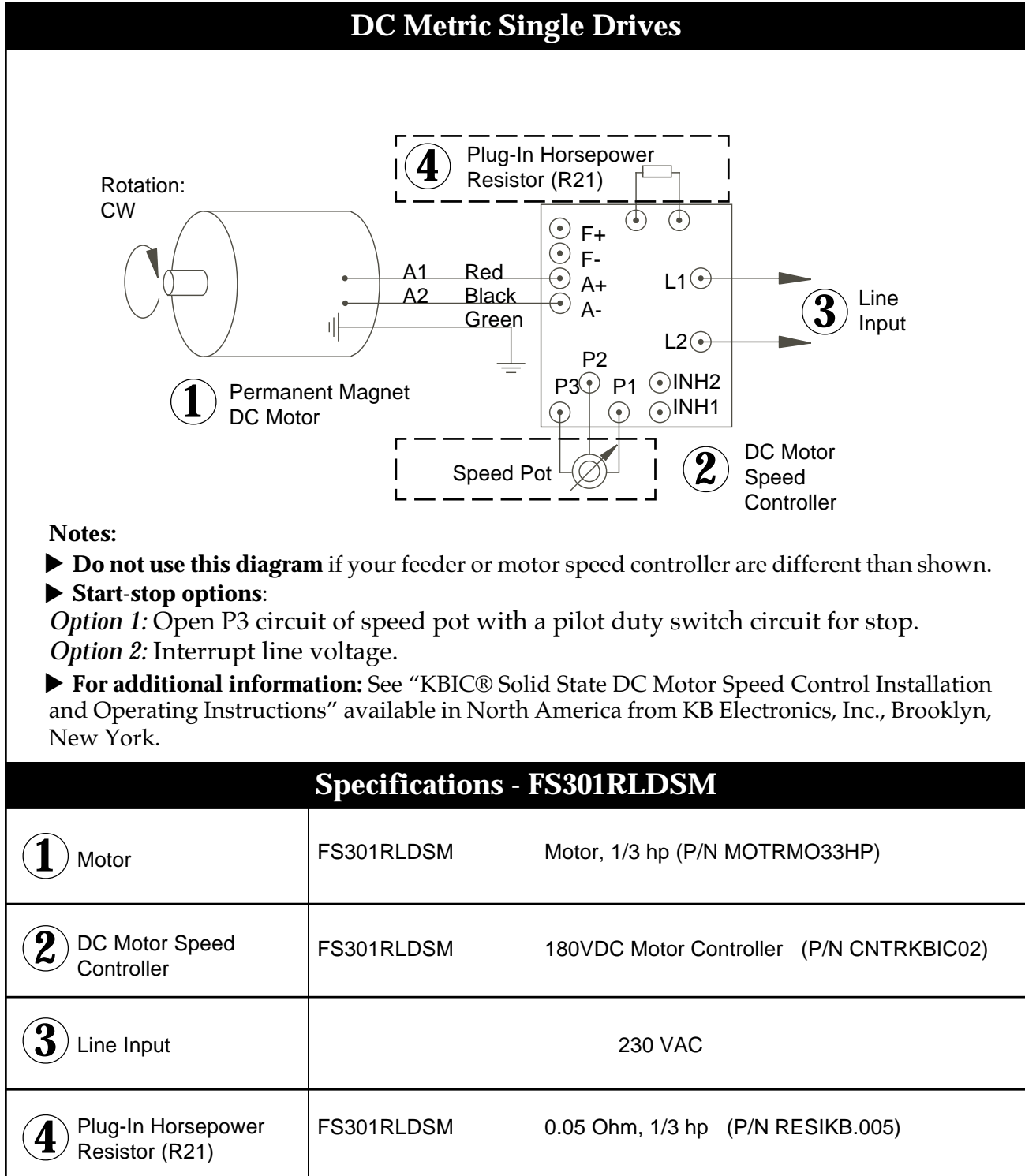


Figure 3-5. DC Metric Suggested Wiring Diagram (FS-30-RD Single DC Motor)

# Preventive Maintenance

## 4

### *General Cleaning*

#### **Outer Frame & Tooling**

The FS-30-RD Centrifugal Feeders are not intended for washdown use. If you need to clean the outer frame, safety covers or tooling, use a damp cloth or a mild household cleaner.

### *Changing the Gear Motor Oil*

The gear motor manufacturer recommends that you change the gear oil after the first 500 hours of operation, and then after every 1500 hours of operation. All other procedures, for both metric and ANSI models, are first performed six (6) months after installation.

### *Reducer Lubrication*

**Speed Reducer—No Lubrication Required.** The brand of speed reducers used in the FS-30-RD feeder are lubricated for life with a synthetic lubricant and requires no regular maintenance.

### *Lubricate Chains and Sprockets*

On all FS-30-RD feeders, grease the disc and rim drive chains and sprockets every six months or 1000 operating hours, whichever comes first.

- ▶ Before beginning, disconnect power and air. Remove exit cover and exit support assembly to gain access.
- ▶ Use standard Moly grease, Lubriplate #3000 (NLGI Grade 2) or equivalent. Turn bowl by hand to expose all links of bowl drive chain.
- ▶ Expose all links of the drive chains by jogging the feeder (turning it on and off). Lock and tagout the FS-30-RD feeder while you are lubricating the chain.



## ***Inspect Chain Tension***

**Step 1—Gain Access.** Improper chain tension wears out sprockets and chains. When lubricating or performing other maintenance tasks, inspect the tension of the chain. If you have not already done so, disconnect power and air, and remove the exit cover and the exit support assembly to gain access.

**Step 2—Inspect Drive Chain.** Midway between sprockets, grasp each chain and move it back and forth. You should be able to move it no more than a total of 1" (25 mm).

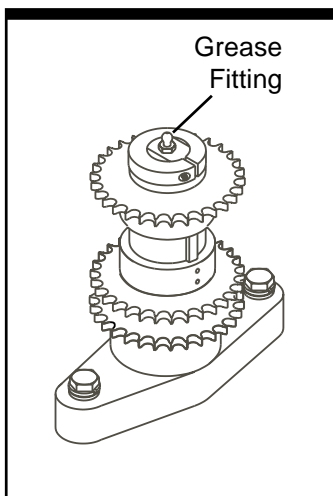
▶ If adjustment is needed, adjust the disc drive chain first. Loosen the idler assembly (see *Figure 4-1*), move the chain forward or back as necessary, and then retighten.

▶ Adjust the bowl drive chain last. Loosen the reducer mounting brackets from the nut plates, move the reducer forward or back as necessary, and then retighten.

**Step 3—Check for Parallel Sprockets.** Check that each set of sprockets is parallel to within 1/32" (0.8 mm). If not parallel, only realign the idler sprockets.

**Step 4—Check for Vibration.** Run the feeder. If vibration is evident, check chain tension for excessive tightness. Vibration may be reduced or eliminated by the realignment of sprockets and increase of total chain deflection from 1" (25 mm) to 1 1/4" (32 mm).

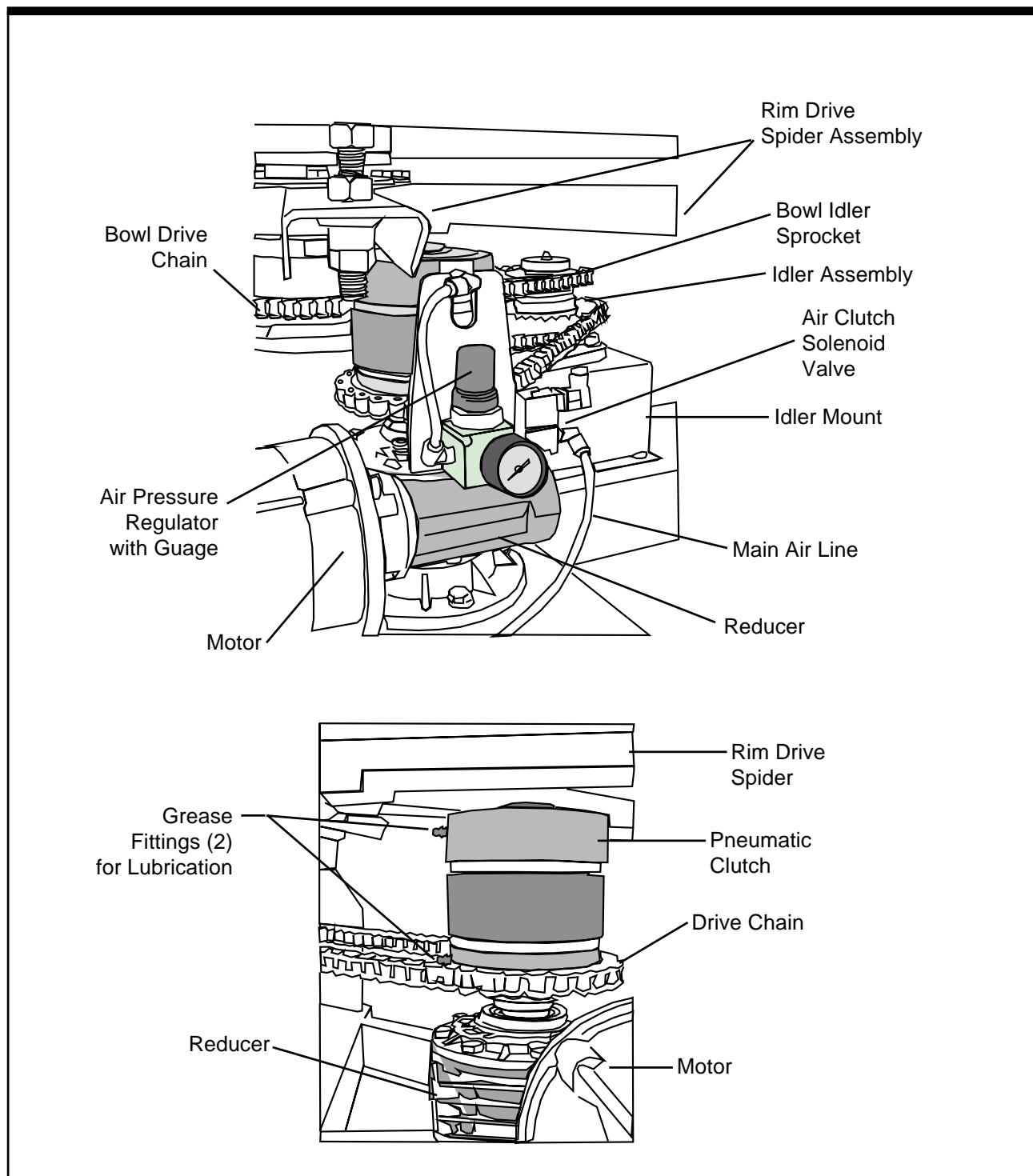
**Step 5—Replace Covers.** Replace covers and connect power and air. Initial and date the Maintenance Log.



**Figure 4-1. Idler Assembly**

## ***Idler Assembly Maintenance***

It's recommended that you grease the idler assembly (refer to *Figure 4-1*), for both metric and ANSI models, every six (6) months after installation. Note the order of assembly (see *Figure 5-3*).



**Figure 4-2. FS-30-RD Drive Train**

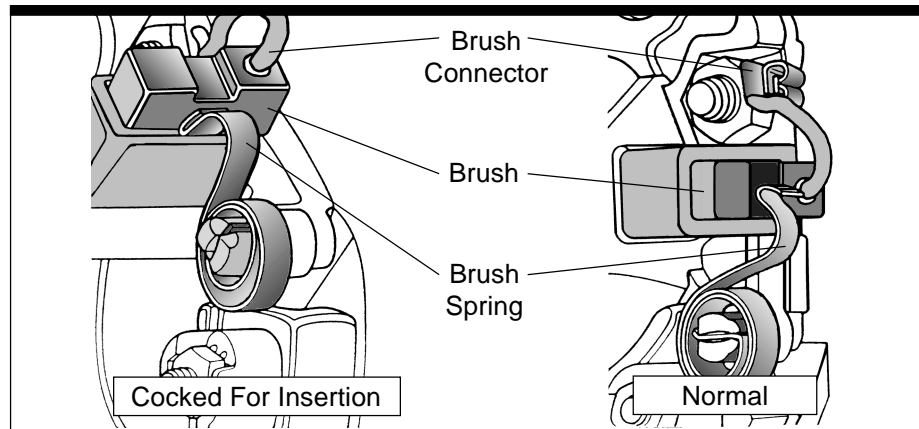


## Inspect/Replace Motor Brushes



**The following procedure applies only to DC motors and should be performed only by qualified personnel. Refer motor repairs to a motor repair specialist.**

**Step 1—Gain Access.** Disconnect power and air. Remove feeder covers as needed to gain access to the motor. Then, remove the motor brush access covers. The insulator guard (a sheet of flexible cardboard-like material covering the access hole) is now visible. Unfold it out of the way, but don't remove it.



**Figure 4-3.**  
**Motor Brushes**  
**(Gasketed Cover**  
**Removed)**



**Step 2—Clean the Motor.** Clean the motor by blowing into the open access hole with compressed air. **Eye protection should be worn to prevent any particles from blowing into the eyes.**

**Step 3—Replace Brushes.** Lift the brush spring from the end of the brush. Remove the brush connector, withdraw the brush and inspect the length. To prevent motor damage, brushes should be replaced before or when they reach a length of 0.575" (15 mm). New brush length is 1.03" (26 mm). Reverse procedure to replace brush. Replace motor access and feeder covers. Connect power and air. Initial and date the Maintenance Log.

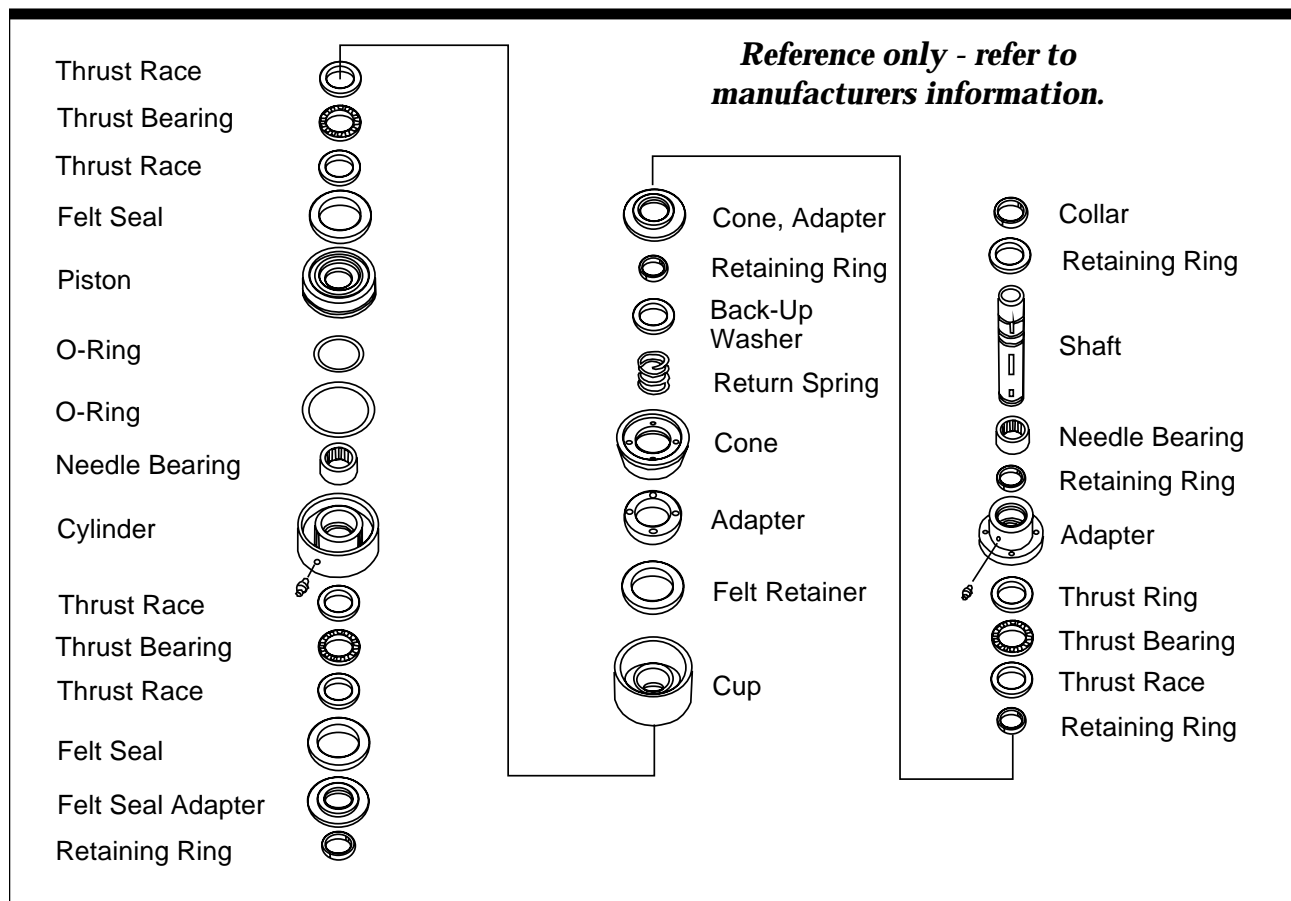
## Lubricate Clutch Assembly

Lubrication will be required after every four (4) weeks of operation. Use a lubricant such as Andersol 786 or equivalent. Two grease fittings are provided for this purpose (see Figure 4-2). After long periods of operation, it may be necessary to disassemble the clutch for cleaning and inspection.



**The clutch is under spring tension. Use care when disassembling.**

To disassemble the clutch, refer to the air clutch manufacturer's technical information (see Figure 4-4).



**Figure 4-4. FS-30-RD Typical Clutch Assembly**



## *Notes*



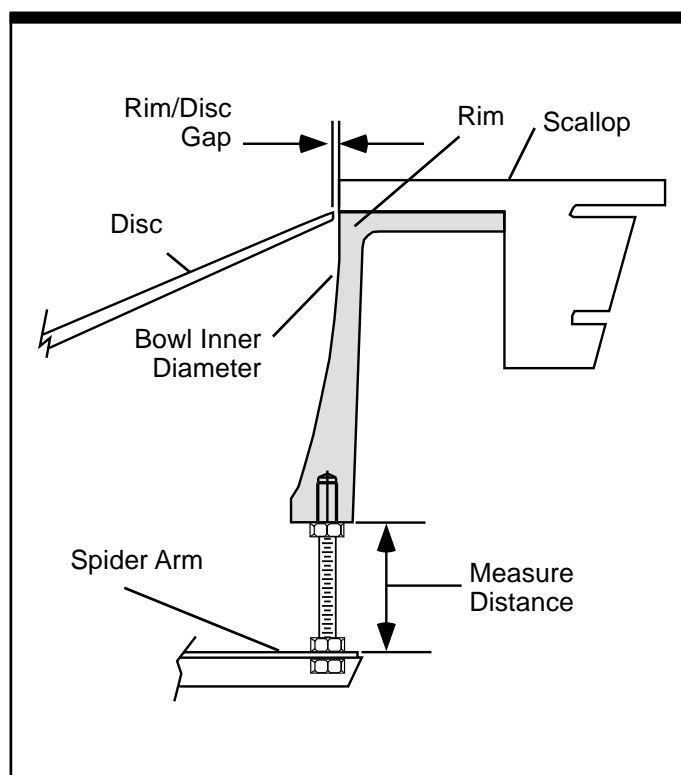
# Repair & Troubleshooting

## 5

### *Replacing or Refinishing a Damaged Bowl*

If the bowl becomes damaged in a way that adversely affects the feeder performance, the bowl must be replaced or refinished.

- ▶ If the damage is slight, recoating with commercial hard coat by a professional metal finisher may correct the problem.
- ▶ Machining must be done in such a way that bowl runout is restored to original tolerances, or the feeder may not operate correctly. If machining is necessary, have the bowl refinished. Refinishing the bowl's surfaces retains the USDA/FDA approved (ultra-hard protective) product contact surface, and corrosion resistance of the bowl.



**Figure 5-1. Side View - Bowl Mounting**

**Step 1—Measuring and Removing the Bowl.** Measure the height between the bottom of the bowl, and the top of the spider arm (where the threaded rod connects the two parts - see Figure 5-1). Loosen and remove the bottom nut on the spider arm (on each of the eight (8) arms) and remove the bowl - pulling it up and away from the feeder.

**Step 2—Replacing the Bowl.** Put the new or refinished bowl in place, then set it to the correct height,  $\pm 0.03''$  (0.8 mm) as you measured in Step 1.

**Step 3—Bowl Runout.** Refer to the section, "How to Set Bowl Runout" described in this chapter.

**Step 4—Check Covers.** Check that all covers are in place before running the feeder.



## ***How to Set Bowl Runout***

Bowl runout needs to be set if the bowl is removed. Adjust runout with power off and bowl drive chain disengaged.

**Step 1—Gain Access.** Disconnect power and air. Remove one of the frame covers.

**Step 2—Remove Bowl Drive Chain.** Remove the master link. Disconnect the bowl drive chain from the bowl spindle sprocket.

**Step 3—Adjust Vertical Runout.** Attach a dial indicator to the inside of any upper frame support. Set the indicator contact point vertical, perpendicular to the rim of the bowl, up to  $\frac{1}{4}$ " (6 mm) from the bowl's upper inside diameter (ID). Loosen jam nuts and locknuts above and below each arm of the bowl spider one arm at a time. Repeat as often as necessary while checking runout. Do not tighten jam nuts until Step 4.

**Step 4—Adjust Horizontal Runout.** Move the indicator contact point horizontal, perpendicular to the inner wall of the bowl, up to  $\frac{1}{4}$ " (6 mm) from the bowl's upper ID. Gently tap the bowl's ID with the palm of your hand or a rubber mallet. Tighten locknuts and jam nuts by hand firmly but not forcibly. Inspect vertical runout and adjust again if necessary. Continue alternating between horizontal and vertical runout until both are within specification.

**Step 5—Check Exit.** Ensure that proper relationship still exists at transition between rim of bowl and output device (deadplate, conveyor, gravity track or powered rollers, etc.).

**Step 6—Check Backup Ring Clearance.** Ensure that proper, as-tooled gap still exists between bottom of backup ring and rim of bowl. (Feeders for most product is tooled with approximately  $\frac{1}{8}$ " gap, but for some product, the gap is less. Consult your as-built documentation for specifications.) At upper frame support, adjust tooling ring up or down if necessary.

**Step 7—Replace Chain & Covers.** Install bowl drive chain. Inspect chain tension, replace covers and re-connect power and air.

## ***Speed Reducer Replacement***

Use the following steps to reuse the existing air clutch when replacing the speed reducer.

**Step 1 – Gain Access.** Disconnect power and air. Remove the frame/safety guard allowing you the best access to the motor and gear reducer. Loosen the mounting bolts and slide the air assembly bracket off.

**Step 2 – Remove the Motor.** Remove mounting bolts and then remove the motor from the speed reducer, leaving the wiring intact. Set the motor off to the side on a secure mount.

**Step 3 – Detach the Air Regulator.** Detach the air regulator bracket from the reducer and disconnect the airline from the clutch. Set aside.

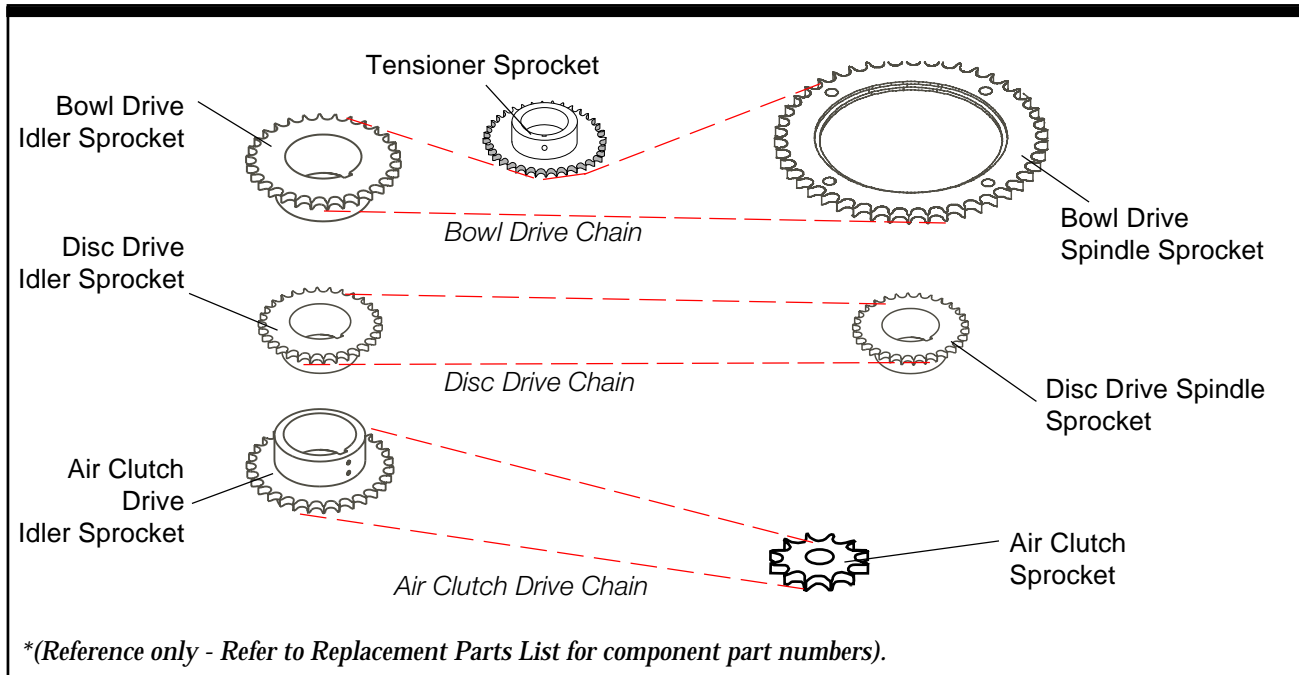
**Step 4 – Remove Old Speed Reducer/Clutch Assembly.** Remove the four mounting bolts on the nut plate at the bottom of the reducer mounting brackets. Slide the speed reducer/clutch assembly towards the center of the FS-30-RD feeder and remove the chain. Completely remove the speed reducer assembly.

**Step 5 – Remove the Air Clutch Assembly.** Remove the bolt located on the top of the Air Clutch (using a hex key). Slide the clutch up and off the reducer output shaft.

**Step 6 – Assemble the Output Shaft/Air Clutch.** The output shaft on the speed reducer is removable and is available as a separate kit. If replacement is required, clean both contact surfaces before assembly and apply any appropriate anti-seize compound to avoid oxidation (rust) and possible seizing of the parts (refer to the manufacturer's technical information sheets that correspond with the output shaft on your equipment.) Slide the air clutch assembly down onto the reducer output shaft (see Figure 5-3) until it bottoms out against the shoulder. Tighten the setscrew. The speed reducer used in the FS-30-RD is lubricated for life with synthetic lubricant and requires no filling before use.



## Chain Drive Nomenclature - Single Drive



**Figure 5-2. Single Drive Sprocket Location Diagram**

**Sprocket Name/Location ..... # of Teeth**

Bowl Drive Sprocket .....	45 Teeth
Bowl Drive Idler Sprocket .....	58 Teeth
Tensioner Sprocket .....	15 Teeth
Disc Drive Spindle Sprocket .....	24 Teeth
Disc Drive Idler Sprocket .....	35 Teeth
Air Clutch Drive Idler Sprocket .....	50 Teeth
Air Clutch Sprocket .....	20 Teeth

**Chain Lengths**

Bowl Drive Chain .....	#40 x 50.5" Long
Disc Drive Chain .....	#40 x 40.5" Long
Air Clutch Drive Chain .....	#40 x 49.5" Long

**Step 7 – Install New Speed Reducer.** Install the new reducer assembly back into the feeder and reattach the two nut plates, securing the assembly to the frame. Do not tighten the bolts yet. Reattach the air regulator bracket and reconnect the airline to the air clutch.

**Step 8 – Install Motor.** Assemble the key to the motor shaft and coat the shaft with anti-seize compound. Insert the motor shaft into the speed reducer input shaft. Align the shafts accurately; improper alignment can result in failure. Rotate the motor to the correct position and firmly secure it to the flange with four hex-head cap screws. Do not allow the motor to "hang" unsupported before fully seating the reducer to avoid damaging the reducer input seal. If the motor does not readily seat itself, check to see if the key has moved.

**Step 9 – Adjust.** Reattach the drive chain and retension, checking sprocket alignments and wiring to insure no damage has occurred. Tighten the nut plate bolts to the frame.

**Step 10 – Inspect After Installation.** During the speed reducer's break-in period, it may run hotter than normal. ***Nevertheless, for maximum life, do not allow the speed reducer to operate continuously above 225 °F at the gear case (for AC motors used in Europe, it is customary to use 60 °C maximum).*** In the event of overheating, check for overloads or high ambient temperatures. Periodically inspect all bolts to make sure they are not loose.

## ***Air Clutch Assembly: Adjustment and Replacement***

The pneumatic air clutch assembly allows the drive sprocket to slip harmlessly in the event of a product jam. Lubricants or surface corrosion on the bushings or the drive sprocket may reduce the effectiveness of the air clutch assembly. The pneumatic clutch assembly should be inspected and/or adjusted if the rim is free wheeling.

**Step 1—Disconnect power and air.** Turn off power and air and tagout/lockout the equipment for repair.

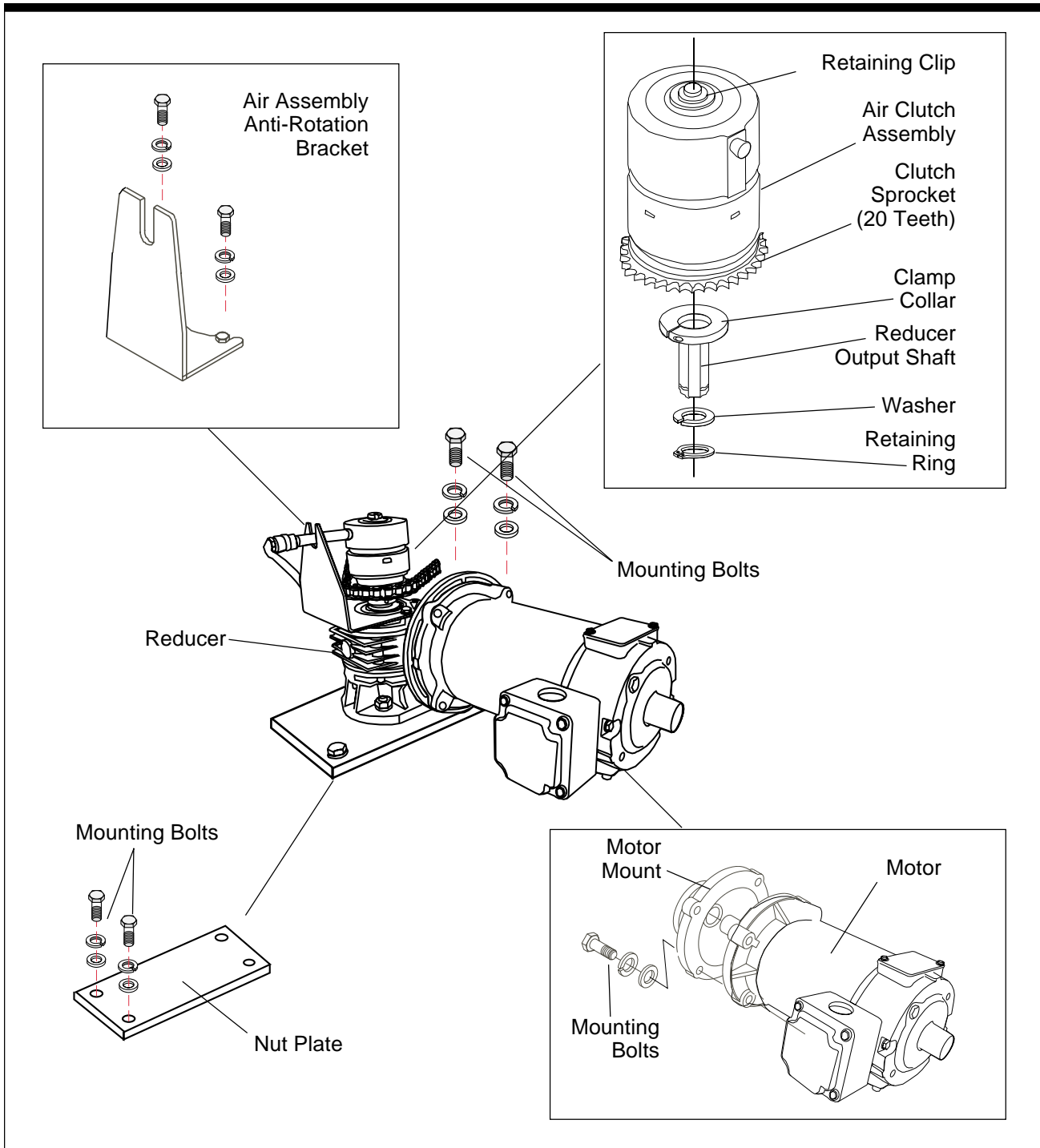
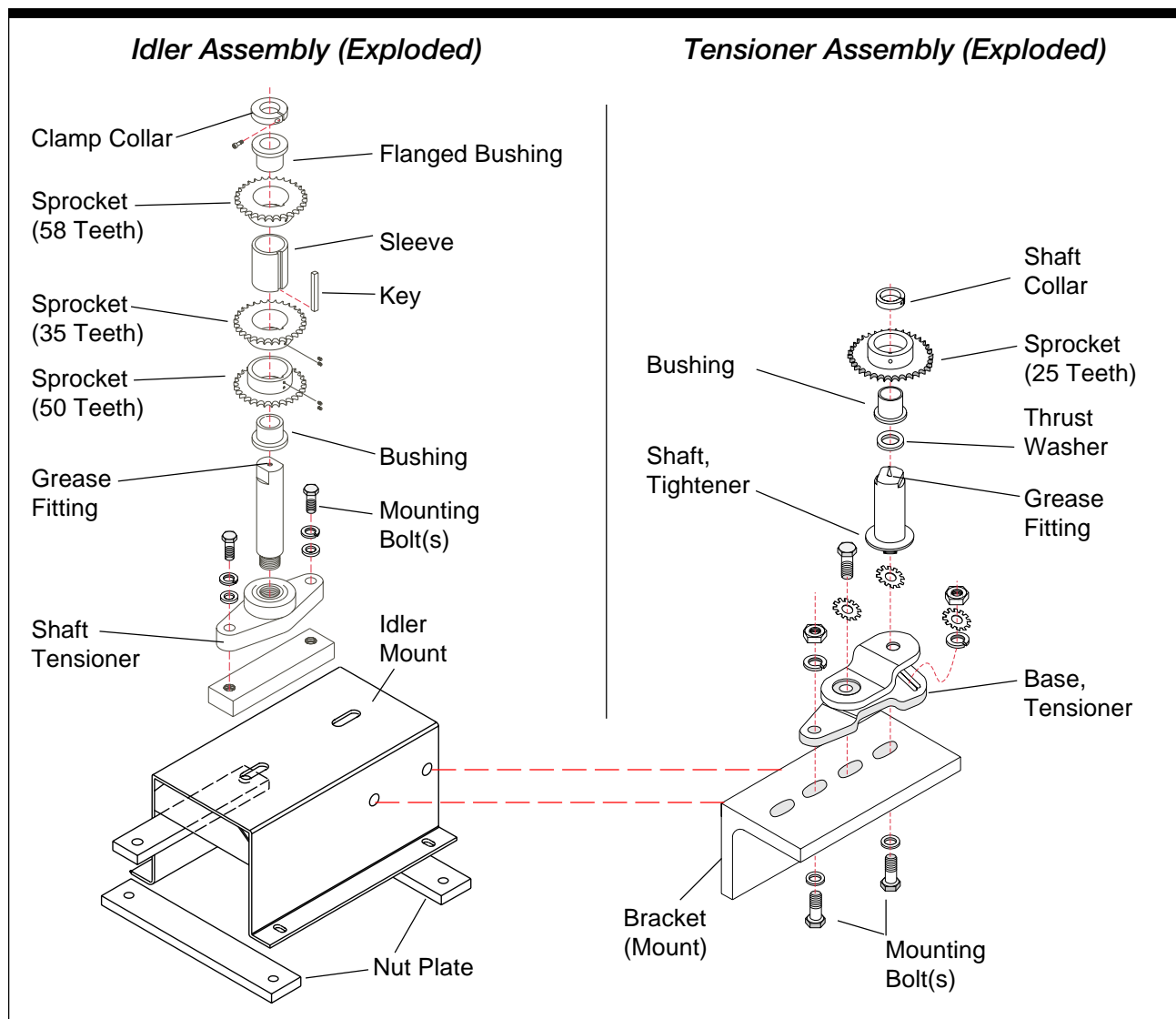


Figure 5-3. FS-30-RD Air Clutch and Motor Assembly - Exploded View

**Step 2—Gain Access.** Remove exit cover(s).

**Step 3—Begin Air Clutch Replacement.** Note the order of the components before replacing the unit (refer to Figure 4-4 and Figure 5-3). Disconnect the air supply, anti-rotation bracket, shaft retaining bolt and setscrew.

**Step 4—Remove the Drive Chain.** Remove the rim drive chain. Inspect and replace any broken or worn parts.



**Figure 5-4. Idler Assembly and Drive Tensioner Assembly** *Continued* ►



**Step 5—Remove the Air Clutch from the Reducer.** Remove the two (2) retaining clips from the top of the air clutch. Loosen the set screws from the clamp collar located under the clutch sprocket. The air clutch assembly will slide off the reducer output shaft.

**Step 6—Remove the Clutch Sprocket.** Remove the clutch sprocket from the air clutch assembly and install it on the new air clutch by removing the bolts holding the sprocket to the clutch.

**Step 7—Reinstall Air Clutch Assembly.** Reinstall the air clutch assembly by reversing the order of removal.

## ***Idler Assembly Component Replacement***

The idler assembly installed in the FS-30-RD is designed for maximum reliability. In the event that you experience problems related to the idler assembly, contact your direct supplier. If component replacement is necessary, note the order of assembly in Figure 5-4.

## ***Major Bearing Replacement***

Major bearings in the FS-30-RD feeder are the upper and lower disc shaft spindle bearings, the upper and lower rim support spindle bearings and the disc support bearing. All major bearings except the disc shaft spindle bearings are identical.

### **Major Bearing Replacement Cautions:**



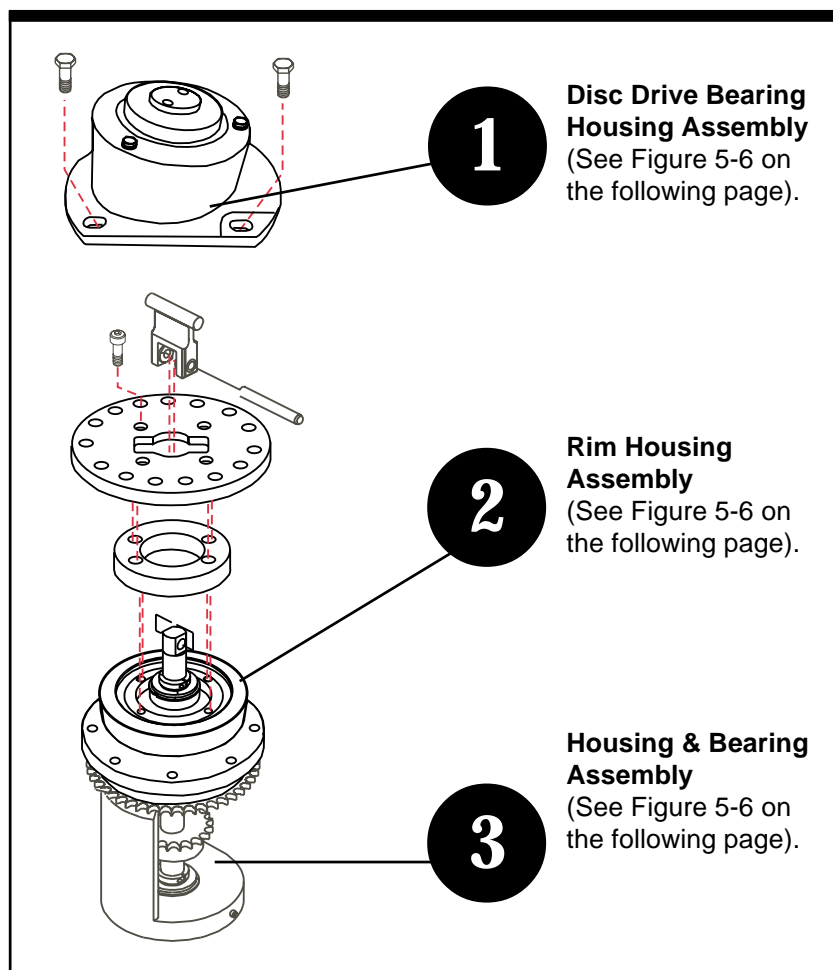
► Eliminate other possible problems before attempting bearing replacement, as substantial disassembly of the feeder is required.

***Carefully note position of any tooling you remove before you begin. Keep chains clean and dry after removal.***

► Most major bearings in the FS-30-RD are preloaded to prevent play. To prevent binding or excessive free play in the bowl, ensure that all bearing housings and the bearings themselves are clean and free of external grease, dirt, nicks or burrs prior to reassembly. If you accidentally damage critical surfaces of the housings, you may need to replace the entire spindle assembly as a unit.



- ▶ Install only 100% identical replacement bearings. In the unlikely event that the bowl will not turn or there is play in the bowl when you are finished, you may need to replace the spindle assembly as a unit or contact Hoppmann Corporation for assistance.
- ▶ To maintain accuracy and prevent play in the bowl, replace both bearings of a pair at the same time. Do not replace only one.
- ▶ Do not swap housings (such as the disc shaft spindle bearing housing) from one FS feeder to another, as critical surfaces may have been custom-machined for zero play in the bowl.
- ▶ Before installing the new bearing, replace any broken or worn hardware. Before installing covers, inspect chain tension.



**Figure 5-5. FS-30-RD Spindle Assembly**

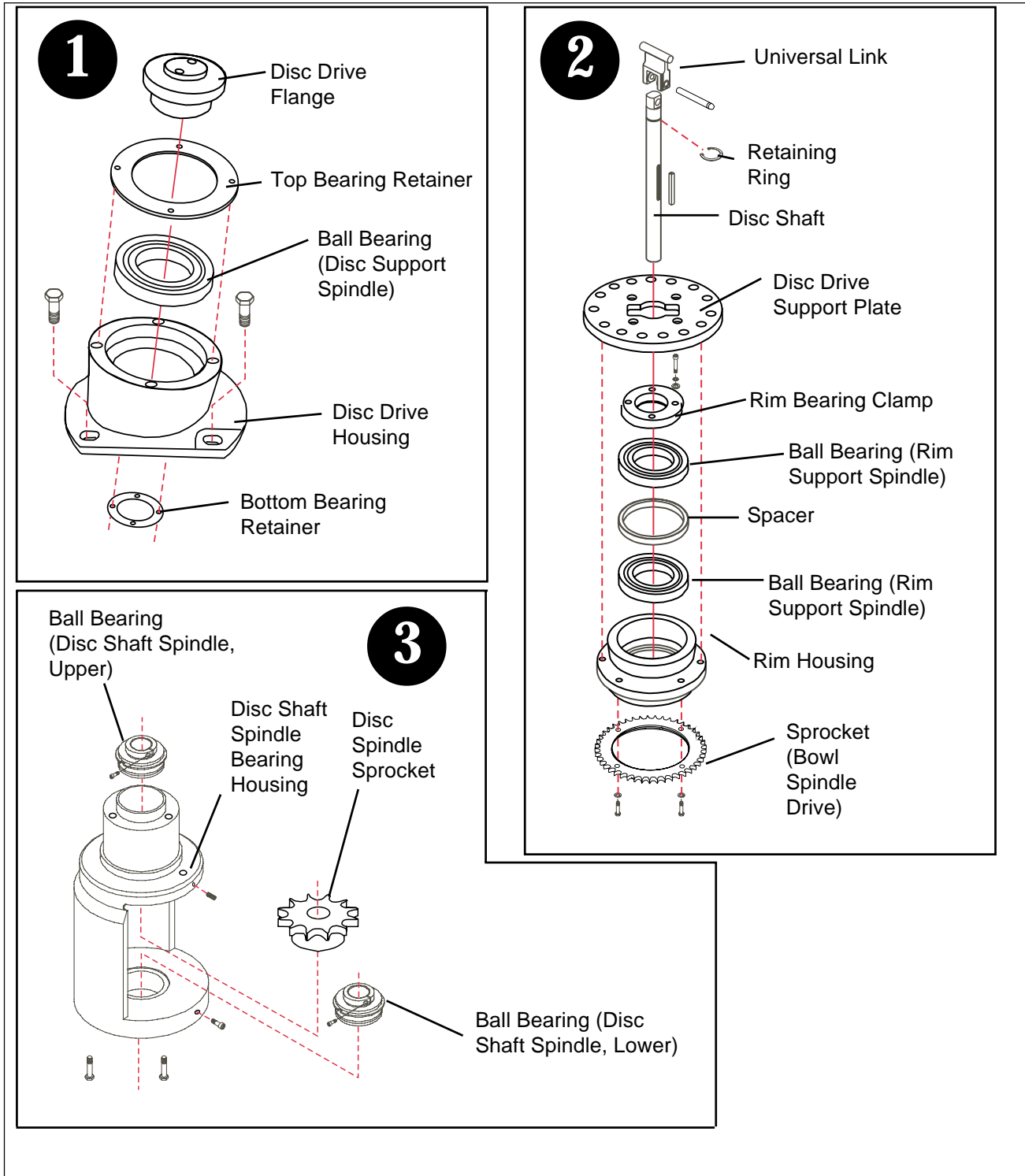


Figure 5-6. FS-30-RD Sectional Spindle Assembly (Single Drive) – Exploded Views

## ***If Product Jam: General Tips***

**Step 1—Inspect The Feeder.** If product jams repeatedly, use the following guidelines to help and determine the possible problem:

- ▶ Is the prefeeder delivering too much product? (The prefeeder should deliver only enough product to the feeder to keep the line running at the required rate.)
- ▶ Is the feeder's bowl speed set incorrectly?
- ▶ Is there a changeover procedure you have overlooked?
- ▶ Is the feeder's main air regulator set incorrectly?

**Step 2—Inspect Your Product.** After checking the feeder, check to see if your product has changed since the last batch:

- ▶ Are they larger? Smaller? A different shape? A different material? Different color? Different quality?
- ▶ If you are orienting freshly molded product, have you made a change in how they are released from the mold? (Are they hotter, drier or stickier, for example?)
- ▶ Finally, if your product has changed, or if you cannot isolate why your product is jamming, contact your direct supplier for assistance.



<b>Problem</b>	<b>Possible Cause</b>	<b>Solution</b>
<b>Rate is too low.</b>	Bowl speed incorrect.	<i>Correctly set bowl speed.</i>
	Feeder overloaded.	<i>Check prefeeder speed. Check prefeeder's time delay relay. Check bowl level sensor in feeder.</i>
<b>Bowl and disc turn but parts jam.</b>	Bowl or prefeeder speed incorrect.	<i>Correctly set bowl and prefeeder speed.</i>
	Air off, too low or too high.	<i>Check air flow. Check pressure at main air regulator.</i>
	Incorrect part.	<i>Verify that feeder is correctly set up to run this part.</i>
	Parts are different than last batch.	<i>Verify that feeder was tooled to run this part.</i>
	Tooling or air jets need adjustment.	<i>Refer to your System Operations Manual or contact your direct supplier.</i>
<b>Surface of parts scuffed or dirty.</b>	Particulate in feeder.	<i>Clean bowl and disc.</i>
	Parts already scuffed.	<i>Check upstream machinery.</i>

**Figure 5-7. FS-30-RD Feeder Troubleshooting**

<b>Problem</b>	<b>Possible Cause</b>	<b>Solution</b>
<b>Feeder won't run at all.</b>	Power off or disconnected.	<i>Turn on power.</i>
	Downstream machinery is full.	<i>Clear downstream machinery.</i>
	Max level sensor blocked or defective.	<i>Check max level sensor of downstream machinery.</i>
	DC motor speed controller "horsepower" resistor missing; internal settings changed; defective speed controller.	<i>Replace "horsepower" resistor; recalibrate to motor speed controller mfr.'s instructions; or replace DC motor speed controller.</i>
	DC motor brushes worn or motor defective.	<i>Replace DC motor brushes; replace motor.</i>
<b>Bowl does not turn.</b>	Part jammed in feeder.	<i>Disconnect power; locate and remove part; then continue operation.</i>
	Torque limiter loose.	<i>Adjust torque limiter</i>
<b>Bowl and disc cog (jerk when moving).</b>	DC motor speed controller defective or internal settings changed.	<i>Replace DC motor speed controller or recalibrate to motor speed controller mfr.'s instructions.</i>
	Loose drive belt.	<i>Tighten drive belt.</i>
<b>Can' t adjust bowl speed high enough.</b>	DC motor speed controller defective or internal settings changed.	<i>Replace DC motor speed controller or recalibrate to motor speed controller mfr.'s instructions.</i>

**Figure 5-8. FS-30-RD Feeder Troubleshooting**



## *Notes*

# Spare Parts

## 6

### ***Notice to Shibuya Hoppmann Customers***

To ensure receiving the right spare part, consult your system operations manual. Refer to the feeder's model and serial number, which was recorded on the front of this manual when ordering replacement or service parts for your prefeeder. *This information is necessary when ordering replacement parts or service.* The system operations manual lists as-tooled components.

### ***Notice to Dealer & OEM Customers***

Some components listed may have been changed by your dealer or OEM to work better with your application. To avoid ordering the wrong spare part, verify the part number listed in this manual when you place your order with your dealer or OEM.

Shibuya Hoppmann Corporation  
13129 Airpark Drive, Suite 120  
Elkwood, Virginia 22718  
**Phone:** (540) 829-2564 Toll Free: (800) 368-3582  
**Fax:** (7540) 829-1724  
[www.hoppmann.com](http://www.hoppmann.com)  
email: [spares@hoppmann.com](mailto:spares@hoppmann.com)



## FS-30-RD Standard Recommended Spares


Part Number	Description	Qty.
FT360010	Clamp, Tooling & Backup Ring	A/R
MFT360600	"L" Bracket, Backup Ring	A/R
FS30SM1202	Tooling Ring Mounting Bracket	A/R
FS30SM1207	"L" Bracket Mounting Clamp	A/R
FT300M9510	Drive Clevis Assembly	1
FS30SM9013	Disc Drive Shaft	1
FT30009008	Disc Clamp	1
MOLDVAC011	Disc Clamp Cover	1
FS200M9012	Disc Drive Flange	1
SPKT402425	Disc Drive Spindle Sprocket, 24 T	1
FT30000600	Bowl Drive Sprocket, 45 T	1
FT480100	Idler Bearing Housing Assembly B	1
FS300M0501	Idler Sprocket - Upper (Bowl Drive), 58 T	1
FS300M0502	Idler Sprocket - Middle (Disc Drive), 35 T	1
FS300M0503	Idler Sprocket - Lower (Air Clutch Drive), 50 T	1
FS300M0506	Sprocket Tensioner, 25 T	1
TORQ000003	Air Clutch, 5/8" Bore	1
FS300M0603	Air Clutch Sprocket, 20 T	1
BRNGASSY01	Bearing Insert, 25mm Cylindrical	2
BRNGBALL07	Ball Bearing	4
BRNGBALL26	Ball Bearing, Double Row	1
DPH0380014	Dowel Pin, Hardened Steel, 3/8 x 1 3/4	1
DRTNSHAF04	Base Tensioner	1
DRTNSHAF01	Tensioner Arm	1
DRTNSHAF03	Tensioner Shaft	1
DRTNSMS402	Shaft Tensioner	1
CHANCS4101	#40 Chain, 101 Links, 50.05" L, Bowl Drive Chain	1
CHANCS4099	#40 Chain, 99 Links, 49.5" L, Air Clutch Drive Chain	1
CHANCS4081	#40 Chain, 81 Links, 40.05" L, Disc Drive Chain	1
FOOTM16180	Level Foot, M16 x 180mm (long) Steel	4


—Not available with this model

**FS301RLDSA, FS301RLDSM, and FS301RLASA, FS301RLASM**



**FS-30-RD Critical Recommended Spares**

<b>Part Number</b>	<b>Description</b>	<b>Critical Quantity</b>	
MOTRP .33HP	Motor, 1/3 hp, 90VDC	1	
MOTRAC0025	AC Motor, 1/4 hp, 230/460		1
REDU000010	Gear Reducer, 100:1, 56 C Face	1	1
CNTRKBIC01	Motor Controller, 90VDC	1	
RESIKB .100	Resistor, 0.100 OHM	1	
 —Not available with this model			
		<b>FS-30-RD - Single Drive DC Motor ANSI FS301RLDSA</b> <b>FS-30-RD - Single Drive AC Motor ANSI FS301RLASA</b>	

<b>Part Number</b>	<b>Description</b>	<b>Critical Quantity</b>	
MOTRM033HP	Motor, 1/3 hp, 180VDC	1	
MOTRMAC033	AC Motor, 1/3 hp, 220/380 3 Phase		1
REDU000010	Gear Reducer, 100:1, 56 C Face	1	1
CNTRKBIC02	Motor Controller, 180DC	1	
RESIKB .005	Resistor, 0.050 OHM	1	
 —Not available with this model			
		<b>FS-30-RD - Single Drive DC Motor Metric FS301RLDSM</b> <b>FS-30-RD - Single Drive AC Motor Metric FS301RLASM</b>	

*Before ordering, please read the notice at the beginning of this chapter.*



## *Notes*



## *Notes*



## ***Warranty***

Hoppmann Corporation warrants that each item of its own manufacture delivered hereunder shall, at the time of delivery and for a period of twelve (12) months thereafter, be free from defects in materials or workmanship; and if any such item shall prove to be defective in material or workmanship under normal intended usage and maintenance during the warranty period, upon examination by Hoppmann Corporation, then Hoppmann Corporation shall repair or replace, at its sole option, such defective item at its own expense; provided, however, that the owner shall be required to ship such defective item, freight prepaid, to Hoppmann Corporation's plant from where it was shipped. The warranty on components not manufactured by Hoppmann Corporation, but a part of the **feeder**, is limited to the warranty provided by the original manufacturer of said components to the extent, and only to the extent, that such original manufacturer actually honors such warranty. **All warranties hereunder are expressly limited to the repair or replacement of defective items as set forth herein, and in no event shall Hoppmann Corporation be liable for special, incidental or consequential damages by reason of any breach of warranty or defect in material or workmanship. Hoppmann Corporation shall not be responsible for repair or replacement of items which have been subjected to neglect, accident or improper use, or which have been altered by other than authorized Hoppmann Corporation personnel.**

**This warranty is in lieu of other warranties, express or implied. All implied warranties, including but not limited to the implied warranties of merchantability and fitness for a particular purpose are hereby excluded.**