

HOOSIER FEEDER™



PREFEEDERS

Reliable Feeding Solutions for Seamless Product Flow

HOOSIER FEEDER™

Hoosier Feeder specializes in delivering high-quality and efficient feeding, orienting, and conveying solutions. Offering custom-built vibratory feeder bowls, centrifugal feeder bowls, conveyor systems, and more. We take pride in serving industries worldwide with dependable automation equipment.

Hopper Elevators

Designed to simplify material handling

- Delivers a steady, controlled flow of materials to the next phase of automation
- Plug-and-play setup for quick, easy installation
- Scalable design adjusts to various discharge heights
- Sealed hopper with hinged Lexan covers for easy monitoring, access, and safety
- Flexible motor mounting configuration
- Hopper cleanout chute for convenience
- Quick delivery options
- Sanitary models available

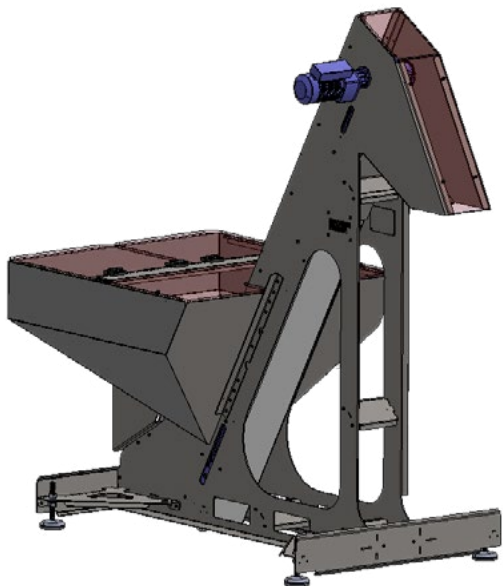

Applications Include:

- Packaging
- Food & Bakery
- Electronics & Appliance
- Cosmetics, Health & Beauty
- Pharma-Nutraceutical
- Medical
- And More!

High Quality & Efficient Parts Orienting Solutions

Our pre-configured Hopper Elevators (Drag-Through Prefeeder) are available in 3 sizes:

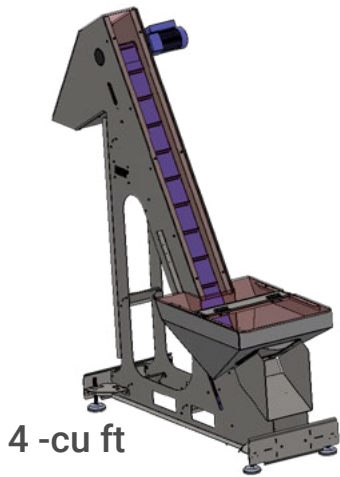

4 -cu ft



15-cu ft



28-cu ft

- Capacity Options: 4 -cu ft, 15-cu ft and 28-cu ft
- Conveyor Widths: 10", 14" and 20"
- Belt Options: Urethane Fabric Belt and Modular Plastic Belt
- Cleat size and spacing based on application
- Custom sizes and designs are also available

Complete Line of Prefeeder Models Available



Z-Frame



Vibratory Hopper



Incline Elevator



Live Bottom Hoppers



Noseover Elevator

A Complete Line of Feeding, Orienting & Conveying Solutions

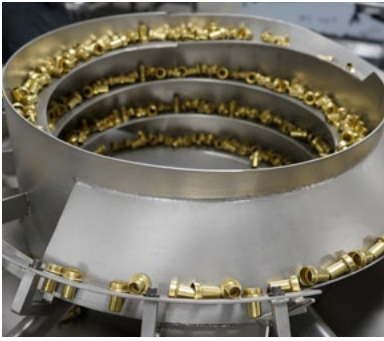

Vibratory Feeders



Centrifugal Feeders



Orienting Conveyors



Product Placement



Prefeeder

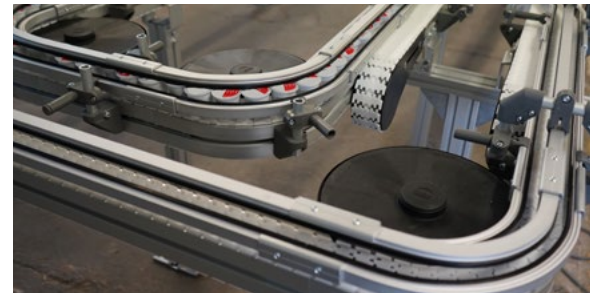

Flexible Chain Conveyors

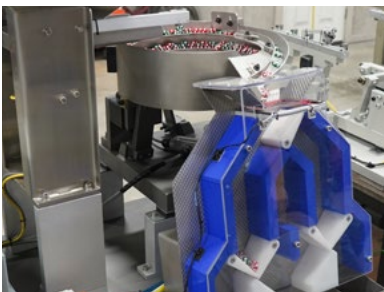

Counting System



Clip Placement



Complete Solutions

HOOSIER FEEDER™

Feeding, Orienting, &
Conveying Solutions

Ph: 765.445.3333 | 888.638.8501

info@hoosierfeedercompany.com

100 W. Morgan Street

Knightstown, IN 46148

www.hoosierfeedercompany.com