

# HAMMERHEAD SWING ARM CLICKER PRESS

## 30 Ton – Data Sheet

sales@americanclickerpress.com | www.americanclickerpress.com | (801) 613-7997 ext: sales

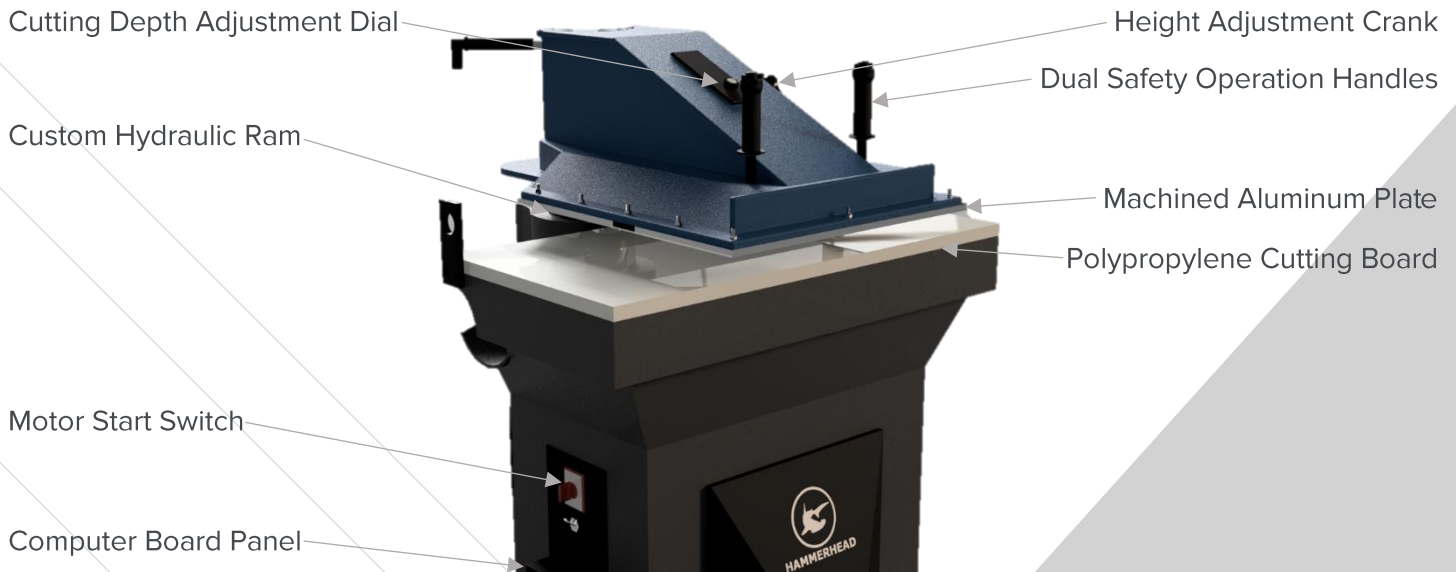

### DESIGN, USE, AND FEATURES

- Two-button operational controls- must be pressed within .25 seconds of each other.
- Head swivels easily to reduce operator fatigue
- Hydraulic-controlled height adjustment (head will lower slowly after press is powered down)
- Ships with free polypropylene cutting board
- Time and pressure-based cutting modes
- Two chamber design for proper ventilation and easy access to motor and electronics
- Energy efficient

Data	30 Ton	
Base Footprint	32.3" W x 33.9" D	
Shipping Dimensions:	48"W x 48"D x 65"H	
Head Size	24" W x 24" D	
Table Size	39.5" W x 19.5" D	
Max Die Dimensions	24" x 19.5"	
Gross Crated Weight	2700 LBS	
Tonnage	30	
Daylight	5"	
Stroke Depth	3.5"	
Stroke Adjustment	1.5"-5"	
Stroke Speed	3.94 in/s	
Oil Capacity	~10 Gallons	
Cutting Pad:	1" Thick Polypropylene	
Cycle	60HZ	
Machine Power	3 Phase 220V	3 Phase 480V*
Amperage	8A	4A
Motor Power	2 HP [1.5KW]	

\* Asterisk indicates an upgrade is needed prior to install

# HAMMERHEAD SWING ARM CLICKER PRESS

## 30 Ton – Data Sheet

sales@americanclickerpress.com | www.americanclickerpress.com | (801) 613-7997 ext: sales

The 30 ton HAMMERHEAD swingarm clicker press has 4.75" of space between the platen and the table when fully open. However, with a ~1" nylon cutting board and ~0.25" cutting die the effective stroke of the head is ~3.5".

The footprint of the machine is shown at the widest parts of the profile. Be sure that your workspace can accommodate the machine and the recommended 30" buffer around the machine.

